



Interim Report

BORDERNETwork Sentinel-Surveillance

**Period of activity:
1.1.2010 – 30.6.2011**

“This Interim Report arises from the project BORDERNETwork which has received funding from the European Union, in the framework of the Health Programme.”



Responsible:

Karin Haar
Matthias Nachtnebel
Osamah Hamouda

Department for Infectious Disease Epidemiology
HIV/AIDS, STI and Blood-borne Infections Unit
Robert Koch-Institute

As at: 30th of June, 2011

1. BACKGROUND.....	4
1.1. PARTICIPATING COUNTRIES AND PARTNERS IN WP 5	4
1.2. LOCAL PARTNERS	5
2. OBJECTIVES.....	6
3. METHODS.....	6
3.1. STUDY DESIGN	6
3.2. STUDY POPULATION.....	6
3.3. SELECTION AND RECRUITMENT OF SENTINEL SITES	6
3.4. DATA COLLECTION	7
3.5. DATA FLOW, PROCESSING AND ANALYSIS.....	7
4. ETHICAL ASPECTS / DATA PROTECTION.....	8
5. INTERIM RESULTS FROM AUSTRIA	9
5.1. COMPOSITION OF THE AUSTRIAN SENTINEL SITES.....	9
5.2. RESPONSE RATE IN AUSTRIA.....	10
5.3. STI SURVEILLANCE DATA AUSTRIA	11
5.4. LIMITATIONS AND FIRST CONCLUSIONS ON THE DATA FROM AUSTRIA	16
6. INTERIM RESULTS FROM BULGARIA	17
6.1. COMPOSITION OF THE BULGARIAN SENTINEL SITES	17
6.2. RESPONSE RATE IN BULGARIA	18
6.3. STI SURVEILLANCE DATA BULGARIA.....	19
6.4. LIMITATIONS AND FIRST CONCLUSIONS ON THE DATA FROM BULGARIA.....	24
7. INTERIM RESULTS FROM ROMANIA.....	25
7.1. COMPOSITION OF THE ROMANIAN SENTINEL SITES	25
7.2. RESPONSE RATE IN ROMANIA	26
7.3. STI SURVEILLANCE DATA ROMANIA	27
7.4. LIMITATIONS AND FIRST CONCLUSIONS ON THE DATA FROM ROMANIA	32
8. INTERIM RESULTS FROM THE SLOVAK REPUBLIC	33
8.1. COMPOSITION OF THE SLOVAKIAN SENTINEL SITES	33
8.2. RESPONSE RATE IN SLOVAKIA	35
8.3. STI SURVEILLANCE DATA SLOVAKIA	35
8.4. LIMITATIONS AND FIRST CONCLUSIONS ON THE DATA FROM SLOVAKIA	41
9. GENERAL DISCUSSION OF THE INTERIM RESULTS AND RECOMMENDATIONS	41
10. FUTURE PLANS	43
11. ANNEX.....	43
11.1. ANNEX I: GLOSSARY	43
11.2. ANNEX II: LIST OF SENTINEL SITES (AS BY 30.6.2011).....	44
11.3. ANNEX III: LIST OF TABLES	47
11.4. ANNEX IV: LIST OF FIGURES.....	47

1. Background

In the context of the gradual EU-Enlargement new challenges evolved; especially the new member countries had to rearrange their health planning and delivering structures. Naturally this upheaval had severe impact on the diagnosis, therapy and prevention of HIV/AIDS and sexually transmitted infections (STI), too.

STIs can cause acute and chronic diseases with severe impact on the quality of life of people as well as on already constraint health budgets. The decrease in bacterial STIs in Western Europe since the seventies was mainly attributed to improved antibiotic treatment and an increased condom-use in the era of a growing HIV-epidemic.

However, some STIs are again on the rise in the last few years in some groups. Many factors have been discussed as potential reasons for this negative development; migration, increased mobility or reduced sexual protective behaviour. In addition, stigmatization of risk and minority groups and lack in access to appropriate healthcare seem to be crucial factors. Therefore, Bordernet was introduced to examine and monitor these factors in selected European border regions. Epidemiological data which later helped to guide prevention and therapy efforts had been gained through the implementation of an STI sentinel surveillance system within selected areas.

Encouraged by this, BORDERNETwork has been built upon the experience accrued by its predecessor project. Integrated biological and behavioural surveillance (IBBS) is still critical in regards of analysing the situation of STIs as well as to improve prevention, diagnostics and therapy accordingly. Therefore, the sentinel surveillance system was extended within the BORDERNETwork project and is performed between 2010 and 2012. Its objectives are to find answers on many public health questions as well as ultimately help funnelling efforts of different stakeholders towards sustainable improvement.

RKI, within this workpackage 5 (WP5), is in charge of implementation and improvement of sentinel surveillance systems in 4 countries (Austria, Bulgaria, Romania and Slovakia) and this report will focus on the results from these countries.

1.1. Participating countries and partners in WP 5

An evidence-based sentinel surveillance system was established in 4 countries, involving 6 partner organisations (4 NGOs in the respective countries) from 5 countries:

- Austria: AIDS Hilfe Wien (Vienna)
- Bulgaria: Health and Social Development Foundation (HESED), Sofia
- Romania: Romanian Association Against AIDS (ARAS), Bucharest
- Slovakia: C.A. PRIMA (Bratislava)
- Germany: Robert Koch-Institut (RKI), Berlin; Sozialpädagogisches Institut Forschung (SPI), Berlin

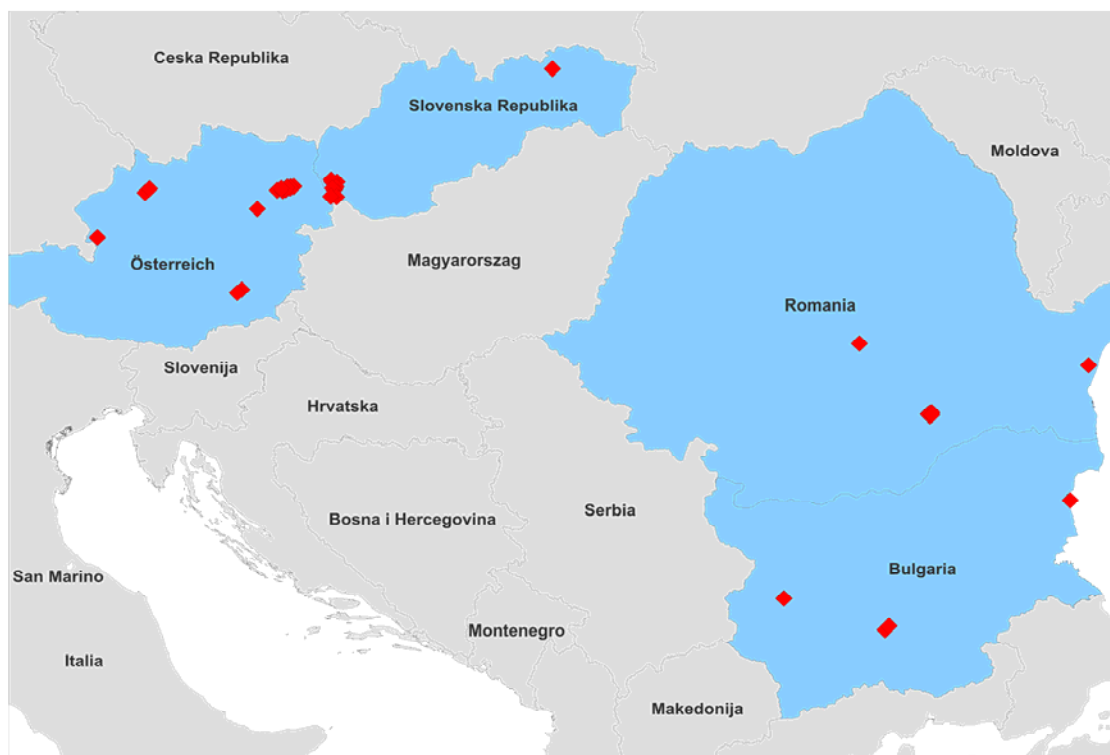

Figure 1: Geography of work-package 5 STI sentinel surveillance institutions

BORDERNETwork's work-package 5 covers the implementation and improvement of STI sentinel surveillance systems in 4 countries: Austria, Bulgaria, Romania and the Slovak Republic (pointed out by shades of blue). Participating sentinel institutions within these four countries are indicated by red diamonds in Figure 1.

1.2. Local partners

The 4 NGOs were in charge of recruiting participating sentinel sites, where patients with STIs could be recruited. According to the variety of healthcare systems in the 4 countries, the participating institutions cover a wide array and include

- Public health offices (specialised on STI-/ HIV- care)
- Specialized outpatient departments
- University clinics
- District Dispensaries for Dermato-Venereal Diseases
- Policlinics
- Practitioners specialized in STI/HIV
- (Private) Consultants (Dermato-Venerology, Gynaecology, Urology)
- Outreach programs
- Drop-in clinics

In the results of this report it seemed therefore appropriate to describe the participating sentinel sites in each country first, as cross-country comparison of results was difficult due to different structures and clients seen.

For detailed information by country see Annex II: List of sentinel sites (as by 30.6.2011)

2. Objectives

The objectives of the STI-Sentinel surveillance are the detection and analysis of frequency and distribution of STI/HIV as well as behavioural factors within participating regions/countries. Whilst (second generation) sentinel surveillance does not claim to collect representative data, its focus is the early detection of trends in certain risk groups, as is the identification of risk behaviour. Therefore, an improvement of diagnosis and therapy and above all a more successful and effective prevention is the ultimate goal of the current project..

3. Methods

3.1. Study design

The design of a second generation sentinel surveillance systems seemed most appropriate to achieve the outlined objectives timely and at a relative low effort and cost. Surveillance of STIs adds additional value to mere HIV surveillance. Since it might take years from contracting HIV to diagnosis, change in “sexual risk behaviour” is reflected much faster by STIs with just a short delay of diagnosis.

Focusing surveillance activities further on subpopulations, such as men who have sex with men (MSM), Roma communities, intravenous drug users (IDU) or commercial sex-workers (CSW) has two additional benefits: first, in countries with low epidemic level of HIV, surveillance of the general population might underestimate the actual HIV numbers and the disease’s spread. Second, the allocation of resources to these sub-populations should most likely produce meaningful results.

In addition, the participation of sites from 4 countries using the same instruments and the experience gained through field visits permits the comparison of different health care systems and approaches towards diagnosis, treatment and prevention of STIs.

3.2. Study population

All patients with new diagnosis of HIV, Syphilis, Chlamydia, Gonorrhoea or Hepatitis B who attended a sentinel site in one of the participating countries during the study period were eligible to participate.

3.3. Selection and recruitment of sentinel sites

The criteria for site selection were to reach a maximum of infected persons in the regions as well as allowing outreach to risk groups. As we assumed that local NGOs know the situation in their respective country, the decision of who to recruit was up to them, depending on the differences of the national health care structures, and the accessibility of certain patient groups. RKI provided scientific feedback to guarantee the formation of a functioning sentinel network. The participation of sites was voluntary and could be ended at any time, however ideally a replacement should be identified as soon as possible. In Bulgaria and Romania, data collection continued from the previous project, whereas all sentinel sites had stopped to report data in Austria and Slovakia, and had to be re-activated at the start of BORDERNETwork in 2010. An initial assessment of all participating sites was essential as the last basic survey was too long ago, and structures within the sites might have changed.

3.4. Data collection

We report all patients who were tested for or had a laboratory-confirmed diagnosis of HIV, Syphilis, Chlamydia or Gonorrhoea infection and who attended one of the sentinel sites during the study period. New cases of Hepatitis B-infection were also reported by sentinel sites in Bulgaria, Slovakia and Romania. After the first site visit and discussion with participating doctors in Austria it was found irrelevant as in the last years only occasional cases of new hepatitis B-infections were found in Austria. Similarly, partner organisations in Romania and Slovakia found it important to collect information on additional diseases, such as Hepatitis C. Moreover, Slovakian partners expressed their interest in studying Human Papilloma-Virus (HPV) in addition, however it was made clear by RKI that strict case definitions would have to be applied (only lab-confirmed diagnoses were to be reported) in order to rule out reporting of (frequently recurring) clinical wart diagnoses.

3.1.1. Basic questionnaire

At the start of the BORDERNETwork sentinel surveillance in January 2010, participating institutions were asked to fill in one each to assess initial information about size, equipment, staff, catchment-area of patients as well as estimated monthly number of patients and the estimated proportion of those tested for STIs and proportion of clients belonging to certain subgroups; i.e. IDUs, MSM, CSW. This survey was only to be done once at start-point.

3.1.2. Monthly questionnaire

On a monthly base, participating institutions were asked to fill in this questionnaire and providing data on aggregated numbers of (male) clients attending the site, performed tests and diagnoses of HIV, Syphilis, Chlamydia, Gonorrhoea and Hepatitis B.

3.1.3. Diagnosis questionnaire

For every positive STI case, doctors were asked to fill in this individual questionnaire providing demographic information, history of STIs, drug usage and the most likely mode of transmission as judged by the reporting physician.

3.1.4. Patient questionnaire

Each patient with an STI then received this questionnaire to be answered by themselves anonymously. Questions asked for information on sociodemographic background, most likely mode and place of transmission, sexual behaviour (number of partners, condom usage) and drug use. Diagnosis and patient questionnaires could later be merged through a coded identifier ensuring data protection and anonymity.

3.5. Data flow, processing and analysis

In a first step, the obtained anonymized questionnaires were sent from the collection sites, the local sentinel sites, to the regional coordinating office (the respective NGO) which performed a first consistency check. If plausible, the questionnaires were further sent to SPI in to perform data entry in a database. Finally, the dataset was forwarded to RKI which performed consistency and plausibility checks and data analysis. All data analyses were performed using STATA 11.0 and PASW Statistics Version 17.0.3. For categorical data, χ^2 test was

performed. For continuous data, medians and means were calculated and compared using Kruskal-Wallis-test and student's two sample t-test. Statistical significance was calculated at the 0.05 level.

Figure 2 depicts the flow of information and data. On one hand, information flows from the collection sites to the place of final data analysis, RKI, in Berlin. On the other hand, computed results were forwarded in the other direction to provide feedback to the regional coordinators and the sentinel institutions.

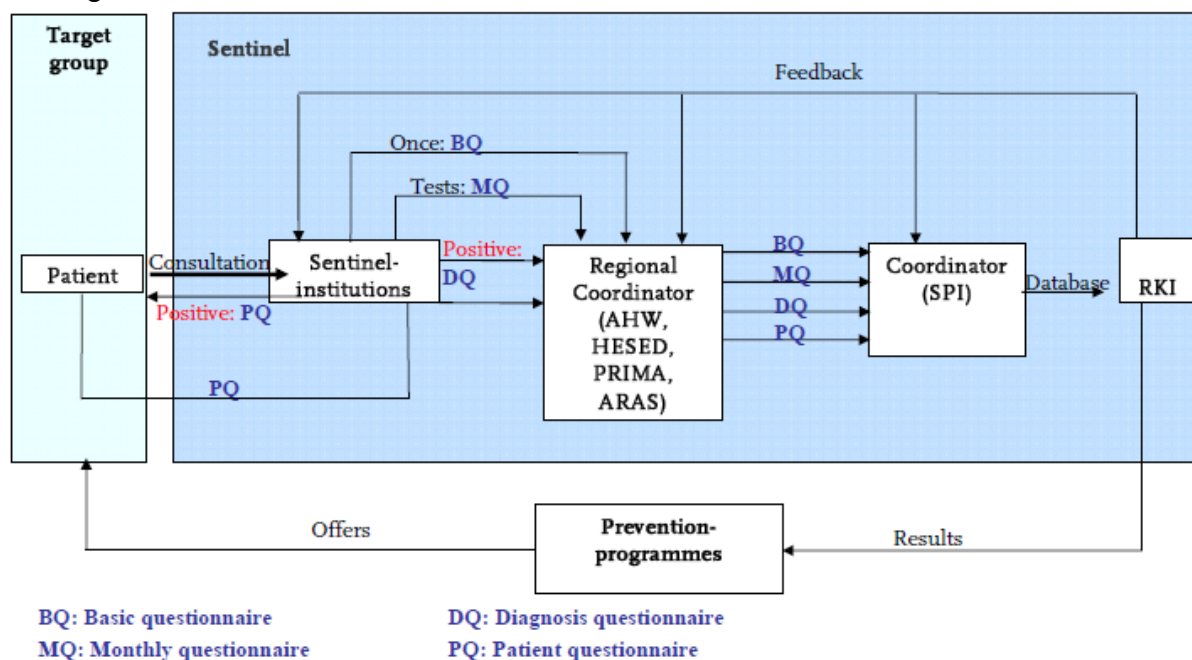

Figure 2: Information flow in the STI Sentinel Surveillance system

4. Ethical aspects / Data protection

STIs are diseases being often associated with stigma and shame for affected clients. Hence, confidentiality was of outstanding importance. Every security measure necessary to guarantee data protection has been put in place; patients' anonymity was maintained and access to data was strictly limited to researchers at RKI and SPI.

Participation of institutions was voluntary and could be ended at any time. No patient-identifying information was collected at any time. Patients willing to participate received a questionnaire and an information sheet; these leaflets contained an explanation of the study, details about data protection measures and emphasizing the sheer optional character of their participation once more. All patient information sheets and questionnaires were available in 17 different languages; ensuring greater acceptability.

The questionnaires were sent in sealed envelopes to the regional coordinators, hence further improving the confidence between patients and local institutions. By all these means we expected to increase the participation and response rate.

Approval was sought by the ethical committees at the Medical University of Vienna in Austria, the Health and Social Development Foundation in Bulgaria, the Bioethics Commission at the National Institute for Infectious Diseases "Prof. Dr. Matei Bals" (INBIMB) in Romania and the Ministry of Health in Slovakia, in all 4 participating

countries. Approval of the research protocol by the national ethic committees was one of the milestones to be produced in WP5.

Interim results from Austria, Bulgaria, Romania and Slovakia

Interim results presented here are based on a dataset we have received on 5th of April 2011 with the data status from April 1, 2011. Some of the partner institutions of the predecessor project Bordernet have never ceased their participation. Therefore, data as presented here contains these institutions, too. The first section of the following results dealing with characteristics of sentinel sites and patients attending these sites draws from basic questionnaires. Thereafter, diagnosis and patient's questionnaires deliver results.

5. Interim results from Austria

5.1. Composition of the Austrian sentinel sites

5.1.1. *Characteristics of Austrian sentinel sites*

We received data from 21 sites, including the locations from the predecessor project; 18 of them joined the BORDERNETwork and 3 participated in the earlier project only. As per April 2011 we received patient and diagnosis questionnaires from 5 of the sentinel sites which continued their participation. Participating institutions were public hospitals and medical universities (8), NGOs with a focus on HIV (4), laboratories (3), a municipal STI-outpatient department (1), a publicly funded project with focus on i.v. drug abuse (IDU) and private practitioners (4).

With 52% (11 of 21) the majority of sites classified their **area of service** as urban whilst 14% (3) served smaller villages and 33% (7) lacked an answer to this question.

The **number of attending STI patients** per site and month was 0 at two sites (10%), 1 to 25 at four sites (19%), 26 to 50 at two sites (10%), 76 to 100 at one site (5%) and more than 100 at 6 sites (29%); six sites (29%) did not specify the number of attendees. The **number of attending HIV patients** per site and month was 0 at two sites (10%), 1 to 25 at nine sites (43%), 51 to 75 at one site (5%) and more than 100 at four sites (19%) whilst five sites (24%) did not answer this question. Sites with a big number of STI-patients (>100) did not necessarily see a huge number of HIV-patients (>100); among sites with more than 100 STI-patients, one site serves 0 HIV-patients and another five sites between 1 and 25 (p -value < 0.01).

A specific **STI consultation** was offered by seven sites (33%) as was an **HIV consultation** with no statistical difference between urban and provincial locations.

The **number of employees** within the STI and HIV sector at these sites varied between 1 and 20 with a mean of 8.

STI testing was anonymous at five (24%) sites and free of charge at five (24%); **HIV testing** was offered anonymously at nine (43%) sites and free of charge at eight (38%).

5.1.2. Attendees of the Austrian sentinel sites

The median proportion of **men among all attending STI-patients** was 60% with a mean of 50% and a range from 15% to 80%. Among **HIV-patients** the median was 70% with a mean of 64% and a range from 20% to 100%.

The median proportion of people of **foreign origin** was 20% and a range from 10% to 90% for both groups, STI- and HIV-patients. The respective means were 27% foreigners among STI-patients and 25% among HIV-patients.

In addition, sites had been asked for an estimation of the proportion of different groups at risk among their patients, stratified by gender (see Table 1).

However, it is difficult to interpret these numbers. The median of groups at risk is calculated by utilizing basic questionnaires; these proportions, however, are not weighted for the size of sentinel sites. It might well be therefore that a large site with a huge proportion of a particular group at risk is underrepresented by the median. In Austria, for example, one site with many patients had CSW as patients mainly.

Table 1: Median of proportions of different risk groups among patients in Austria by sex (multiple answers possible)

		Median	Range
Women	Sex workers (CSW)	5%	0-85%
	i.v. drug user (IDU)	20%	0-70%
	Heterosexual	95%	15-99%
	Homo-/bisexual	24%	5-95%
Men	i.v. drug user (IDU)	10%	1-30%
	Heterosexual	75%	5-95%

5.2. Response rate in Austria

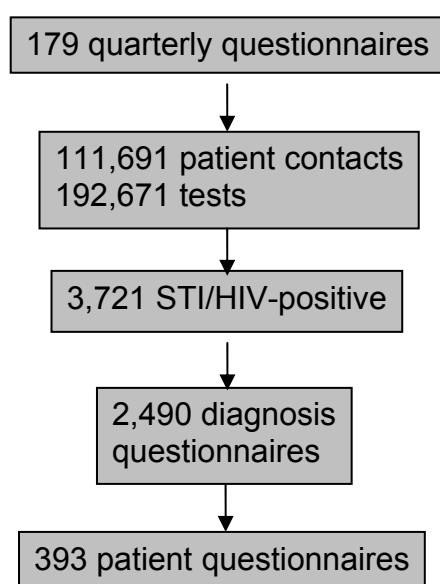

Physicians from participating institutions sent a diagnosis questionnaire in 67% (2,490/3,721) of patients with a positive diagnosis (see figure 1). Patients completed the patient's questionnaire in 16% (393/2,490). This low proportion is at least partly the result of mandatory STI-examinations in CSW in Vienna who might therefore reject participation.

Figure 3: Flow chart of questionnaires and number of positive tests in Austria, 2006-2007 and from 2010

5.3. STI Surveillance data Austria

In Austria, the STI sentinel surveillance was performed in 2006 and 2007 under the Bordernet-project and from 2010 on as part of BORDERNETwork.

5.1.1. Performed tests, positivity rates and reported cases by STI

Since the start of the sentinel surveillance in Austria, a total of 192,671 tests have been performed in 111,691 clients. The higher number of tests than clients results from more than one test being performed in the same patient. In these data from the monthly questionnaires, doctors stated that 25,591 of all clients (22.9%) were men. Most tests were performed for gonorrhoea, whereas the highest number of positives was found for chlamydia. Chlamydia also had the highest positivity rate. For each positive test, doctors had to send one diagnosis questionnaire per patient. The reported STI cases were highest for chlamydia. In almost 75% of positive diagnosis, doctors filled in an individual diagnosis questionnaire, whereas they only did so for 46% of syphilis-cases. Only 13-24% of patients filled in a corresponding patient questionnaire, depending on STI, as shown in Table 2.

Table 2: Total number of lab tests, positive tests and positivity rate (in %), number and proportion of reported STI cases and number and proportion of corresponding patient questionnaires by STI, Austria

AUSTRIA	Monthly questionnaire		Diagnosis Questionnaire	Patient Questionnaire
STI	# lab tests	# positive tests (%)	# reported STI-cases (%)	# corresponding questionnaires (%)
Chlamydia	58,423	2,323 (4.0)	1,734 (74.6)	226 (13.0)
Gonorrhoea	65,187	896 (1.4)	640 (71.4)	153 (23.9)
HIV	39,738	143 (0.4)	96 (67.1)	12 (12.5)
Syphilis	29,323	359 (1.2)	164 (45.7)	38 (23.2)

5.1.2. STI-Trends

The positivity rate was calculated by the number of positive tests over the number of all performed tests by STI. In Austria, the positivity rate was highest for chlamydia in almost all reported quarters. In the second quarter 2010, the positivity rate seemed to be highest for syphilis; however, numbers of performed tests were very small. Only 167 tests were performed compared to routinely reported 2,500 to 3,000 tests per quarter.

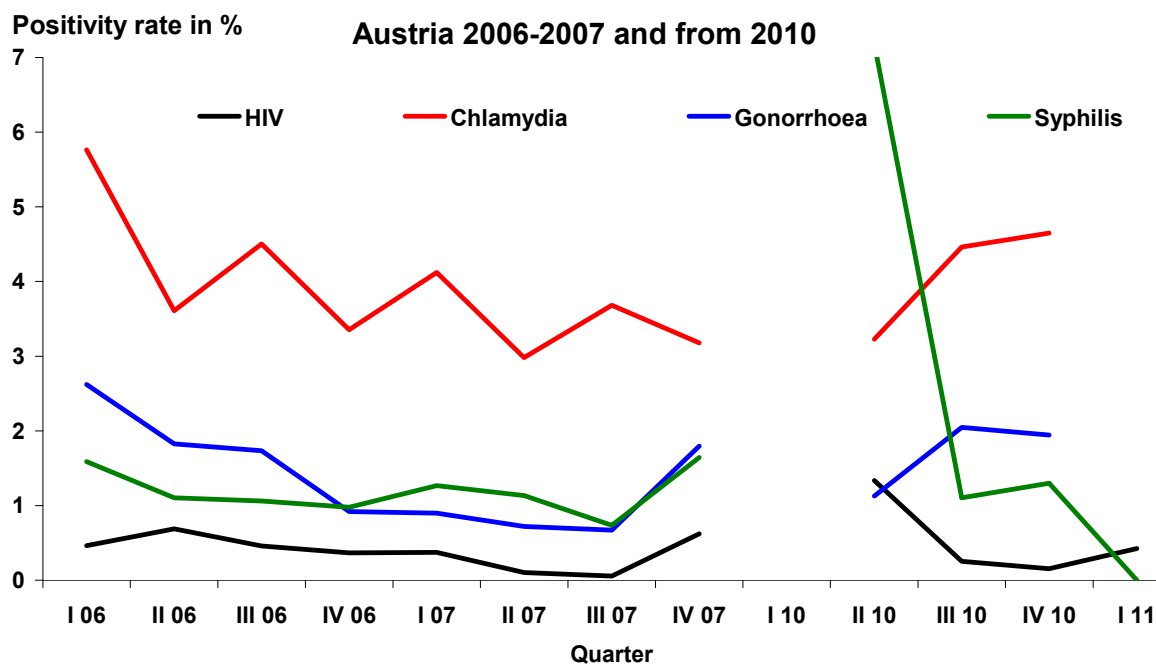

Figure 4: Positivity rate by STI in Austria over time

5.1.3. Sociodemographic characteristics of patients with STIs

With 63% of patients with an STI/HIV being female, their proportion was more than two thirds. There were statistically significant differences in the age of patients, with a median age of 30 years males being older than females. Also the proportion of migrants was with 73% more than double as high among females. Almost two thirds of females were CSW. Significant differences existed also for intravenous drug use which was higher among female patients. In addition, females had more frequently a history of a previous STI; this proportion was almost one third (see Table 3).

Table 3: Demographics of patients with an STI/HIV in Austria

	Men (n=920)	Women (n=1,542)
Percentage	37%	63%
Age, median (years)	30	25
Migrant	33% (260/779)	73% (1,008/1,390)
Men who have sex with men (MSM)	20% (180/920)	--
Commercial sex worker (CSW)	4% (36/920)	67% (1,037/1,542)
i.v. drug use	0.4% (3/775)	3% (37/1,334)
History of STI	16% (151/920)	29% (442/1,542)

Data from diagnosis and patient questionnaires. 19 sets of questionnaires without indication of gender excluded.

The majority of male patients originated from Austria followed by Central European countries. Other nationalities were less frequently reported. In contrast the origin of females: the majority originated from Central Europe, Austrian origin was second (see Figure 5).

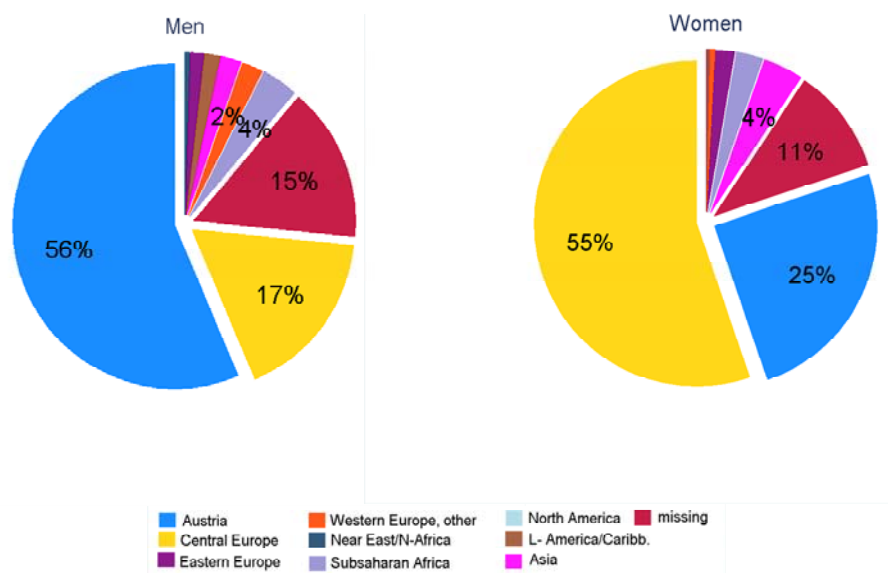

Figure 5: Origin of patients with STI in Austria stratified by gender (n=2,462)

5.1.4. Epidemiology of STIs

The most commonly diagnosed STI was chlamydia with almost 3-times the cases of the second most common, gonorrhoea. Chlamydia and gonorrhoea were diagnosed more frequently among females; conversely the gender distribution for syphilis and HIV (see Figure 6).

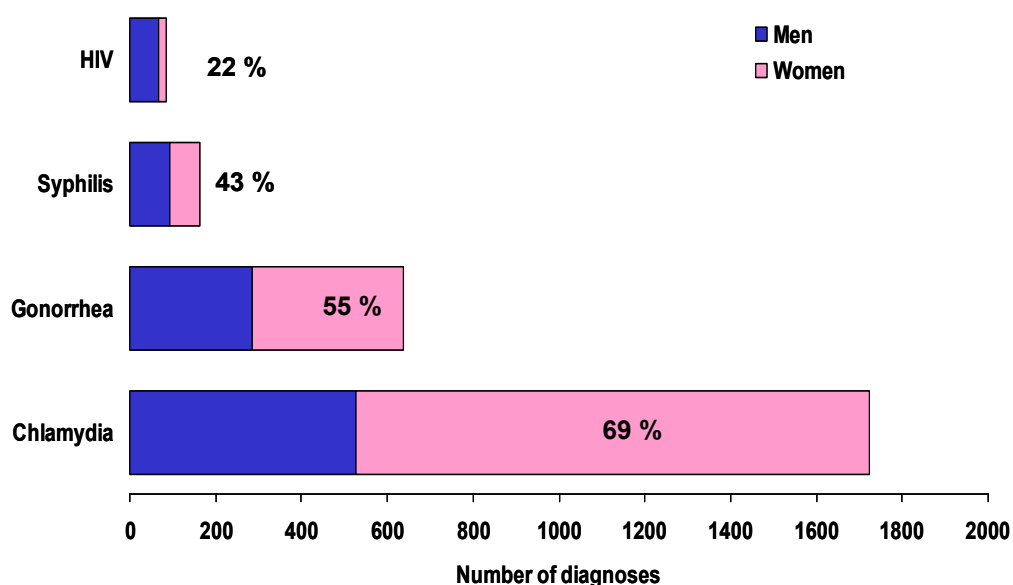

Figure 6: Number and gender distribution of STI/HIV among patients at Austrian sentinel sites

Stratified by STI/HIV there were statistically significant differences in age, male patients being older than females. In addition, median age was highest for syphilis

patients and lowest for patients with chlamydia. More patients were migrants among females (see Table 4). The highest number of male patients with STI belonged to the age group 25 to 29 years, the lowest number to the group aged 60 and more. Female patients exhibited a similar pattern with a slight shift to the left: the age group of 20 to 24 years contributed the biggest number; patients aged 60 and more the smallest.

Table 4: Characteristics (age, migrant, MSM and CSW) of patients in Austria by STI, stratified by gender

	Chlamydia		Gonorrhoea		Syphilis		HIV	
	Men (n=526)	Women (n=1,196)	Men (n=285)	Women (n=353)	Men (n=94)	Women (n=70)	Men (n=67)	Women (n=18)
Age, median (years)	29	25*	30	25*	36	28*	33	24*
Migrant	121 (23%)	725* (61%)	107 (38%)	276* (78%)	33 (35%)	61* (87%)	25 (37%)	11 (61%)
MSM	29 (6%)	--	62 (22%)	--	57 (61%)	--	42 (63%)	--
CSW	12 (2%)	754* (63%)	12 (4%)	282* (80%)	11 (12%)	58* (83%)	3 (4%)	10* (56%)

* statistically significant

Co-infection of more than one STI and/or HIV was most commonly diagnosed for gonorrhoea and chlamydia. This co-infection was frequently diagnosed in both genders; however, more often in women (see Table 5) with almost a quarter of women with gonorrhoea being simultaneously infected with chlamydia (23.5%).

Table 5: Co-infections of chlamydia, gonorrhoea, syphilis and HIV in Austria by gender

	Chlamydia		Gonorrhoea		Syphilis		HIV	
	Men (n=526)	Women (n=1,196)	Men (n=285)	Women (n=353)	Men (n=94)	Women (n=70)	Men (n=67)	Women (n=18)
Chlamydia	--	--	41 (14.4%)	83 (23.5%)*	3 (3.2%)	8 (11.4%)*	1 (1.5%)	1 (5.6%)
Gonorrhoea	41 (7.8%)	83 (6.9%)	--	--	1 (1.1%)	5 (7.1%)*	1 (1.5%)	1 (5.6%)
Syphilis	3 (0.6%)	8 (0.7%)	1 (0.4%)	5 (1.4%)	--	--	4 (6%)	1 (5.6%)
HIV	1 (0.2%)	1 (0.1%)	1 (0.4%)	1 (0.3%)	4 (4.3%)	1 (1.4%)	--	--

* statistically significant, only patients with known gender included

Another question concerned the history of a previous STI or diagnosis of HIV in regards of the current disease (see Table 6). Almost a tenth of patients with chlamydia and every fifth with gonorrhoea had been diagnosed with the same disease before.

Table 6: Previous diagnosis of STI or HIV by current disease in Austria

	Chlamydia (n=1,734)	Gonorrhoea (n=640)	Syphilis (n=167)	HIV (n=87)
Chlamydia	9.5%	8.6%	4.8%	3.4%
Gonorrhoea	7.4%	17.7%	8.4%	3.5%
Syphilis	3.1%	7.5%	9.6%	9.2%
HIV	0.4%	2.5%	13.6%	--

5.1.5. Groups at risk and risky behaviour

In addition to demographics and epidemiological data we collected behavioural information via diagnosis and patient questionnaires. Especially, questions such as the most likely source of infection, number of sex partners, condom use and drug use were subject to enquiries. Below we present some examples of these questions and related answers.

Furthermore, we compared the use of condoms among males and females (see Figure 7). Males were in general less likely to use condoms; they used less frequently condoms with their regular partner ($p = 0.015$), a casual partner ($p = 0.08$) and a CSW ($p = 0.001$).

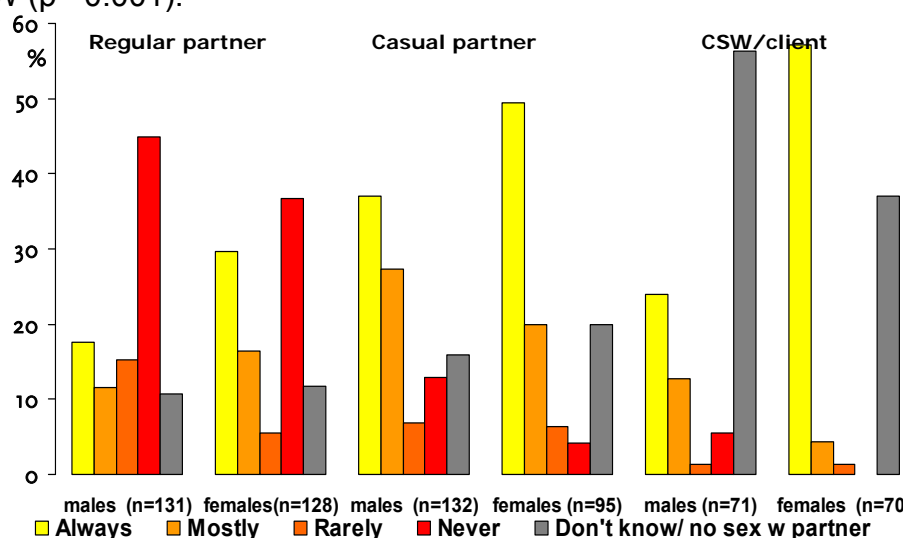

Figure 7: Condom use with regular and casual partner and CSW among patients attending Austrian sites, by gender

Number of sex partners significantly differed between males and females ($p=0.006$). Males ($n=164$) had a median of 2 and a mean of 9 sex-partners within the last 6 months while females ($n=120$) had a median of 2 and a mean of 20 sex-partners in this period.

Attendants of Austrian sentinel sites were frequently CSW, therefore the number of sex-partners among females was increased due to this group.

The patient's questionnaire contained an item asking for the most likely source of the current infection. Table 7 shows the results stratified by group at risk. MSM assumed most often a casual partner as source of their infection. Either an unknown or a casual partner was the main source of infection for FSW. There were significant differences between genders among migrants: males suspected casual partners more often while women didn't know ($p=0.03$). Similarly, male patients aged less than 25 years suspected mainly a casual partner whilst females of the same age group most likely suspected their regular partner ($p=0.012$)

Table 7: Suspected source of current infection (from patient's questionnaire) by group at risk in Austria

	MSM (n=60)	FSW (n=118)	Migrant ♀ (n=115)	Migrant ♂ (n=78)	<25 years ♀ (n=72)	≥25 years ♂ (n=47)
Regular partner	11.7%	21.2%	27%	19.2%	38.9%	25.5%
Casual partner	71.7%	31.4%	29.6%	52.6%	25%	51.1%
CSW	1.7%	2.5%	1.7%	6.4%	1.4%	6.4%
Client	1.7%	12.7%	7.8%	2.6%	9.7%	2.1%
Other/ don't know	13.3%	32.2%	33.9%	19.2%	25%	14.9%

5.4. Limitations and first conclusions on the data from Austria

Participating institutions varied substantially in regards of attended patients and, subsequently, number of sent questionnaires. One particular institution, a municipal STI clinic in charge of mandatory health checks for CSW, contributed more than 50% of submitted diagnosis questionnaires from Austria. Hence, the proportion of CSW is adequately high. On the other hand, the low patient response rate in Austria might be associated with that institution as well. A mandatory health examination is not the optimal stage for a voluntary participation in a survey.

However, data being available so far demonstrated a rather stable trend for all STI under observation. We identified a high proportion of migrants among patients with STIs which is most likely due to a high proportion of migrants among CSW working in Austria. A higher proportion of STI, not HIV, has been diagnosed among female than male migrants. In addition, median age of patients with an STI is lower in females. The most frequently diagnosed STI was chlamydia.

Further differences existed in regards of condom use and suspected source of infection. Among people aged less than 25 years males suspected mainly a casual partner whilst females assumed their regular partner. This effect is probably partly due to males belonging to the group of MSM. Moreover, males were less likely to use condoms.

Comparing the sentinel data acquired in Austria to the German STD-sentinel-data, many similarities in patients with STIs can be found and data are comparable. In Austria however, not as many MSM have been recruited, as many of the Austrian sentinel sites are not particularly focussed on this group. In the future, possible extension of sentinel sites that particularly provide health care for MSM should be emphasized.

In total, the participation of sentinel sites in Austria was very satisfying and data quality was good. For further improvement, doctors could be asked to complete more individual diagnosis questionnaires for patients with syphilis, and in general, the response rate of patients could be emphasized. Including more sentinel sites outside of Vienna would also allow us to draw more conclusions regarding the capital versus more rural areas and hence interpret geographic data.

6. Interim results from Bulgaria

6.1. Composition of the Bulgarian sentinel sites

6.1.1. *Characteristics of Bulgarian sentinel sites*

As per April 2011, we received basic questionnaires from 5 institutions; all of them have been sending data as well. Participating institutions were district dispensaries for dermato-venereal diseases (2), medical universities (2) and one hospital.

With 80% (4 of 5) the majority of sites classified their **area of service** as urban whilst 20% (1 of 5) served a rural area.

The **number of attending STI patients** per site and month was 1 to 25 at one site (20%), 76 to 100 at one site (20%) and more than 100 at 3 sites (60%). The **number of attending HIV patients** per site and month was 1 to 25 at one site (20%), 26 to 50 at two sites (40%), 51 to 75 at one site (20%) and between 76 and 100 at another one (20%). Number of attended STI and HIV patients showed correlation in the sense that sites with many STI-patients tended to see many HIV-patients. Among sites with more than 100 STI-patients one site attends 26 to 50, one 51 to 75 a third one 76 to 100 HIV-patients (p-value= 0.4).

A specific **STI consultation** as well as an **HIV consultation** was offered by all sites (100%).

The question about **number of employees** within the STI and HIV-sector had been answered by just one institute (20%) which has 2 employees in this area.

STI testing was anonymous at all (100%) sites and free of charge at three (60%); **HIV testing** was offered anonymously at all (100%) sites and is free of charge at all as well (100%).

6.1.2. Attendees of the Bulgarian sentinel sites

The median proportion of **men among all attending STI-patients** was 50% with a mean of 54% and a range from 43% to 70%. Among **HIV-patients** the median was 57% with a mean of 65% and a range from 50% to 90%.

The median proportion of **people of foreign origin** was 1% with a range from 0% to 10% among **STI- and HIV-patients**. The respective means were 3% foreigners among STI-patients and HIV-patients.

In addition, sites had been asked for an estimation of the proportion of different groups at risk among their patients, stratified by gender (see Table 8).

However, it is difficult to interpret these numbers. The majority of patients among both genders belonged to heterosexual persons; however, the number of attended patients per site didn't enter this calculation. Therefore, the percentage of CSW or IDU might be significantly different from these numbers when considering patients instead of sentinel sites.

Table 8: Median of proportions of different risk groups among patients in Bulgaria (multiple answers possible)

		Median	Range
Women	Sex workers (CSW)	5%	0-10%
	i.v. drug user (IDU)	1%	1-70%
	Heterosexual	90%	90-99%
	Homo-/bisexual	10%	1-20%
Men	i.v. drug user (IDU)	1%	0-80%
	Heterosexual	90%	80-90%

6.2. Response rate in Bulgaria

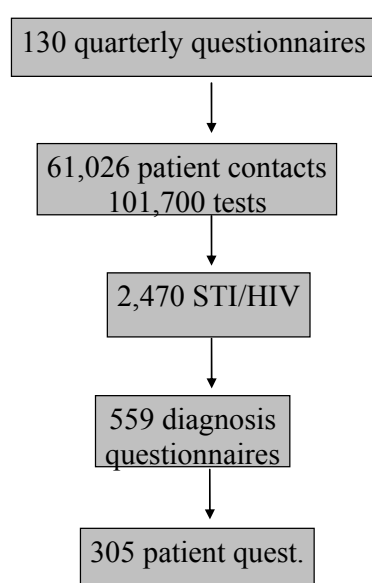

Physicians from participating institutions sent a diagnosis questionnaire in 23% (559/2,470) of patients with a positive diagnosis (see Figure 8). Patients completed the patient's questionnaire in 55% (305/559).

Figure 8: Flow chart of questionnaires and number of positive tests in Bulgaria, since 2008

6.3. STI Surveillance data Bulgaria

In Bulgaria, the STI sentinel surveillance was introduced in 2008 and data were reported continuously until today.

6.1.1. Performed tests, positivity rates and reported cases by STI

Since the start of the sentinel surveillance in Bulgaria in 2008, a total of 101,700 tests have been performed in 61,026 clients. In these data from the monthly questionnaires, doctors stated that 30,780 of all clients (50.4%) were men. Most tests by far were performed for syphilis, where also the highest number of positives was found. However, chlamydia had the highest positivity rate. In 75% of positive HIV diagnoses, doctors filled in an individual diagnosis questionnaire, whereas they only did so for 12% of syphilis-cases. The patient response rate varied between 44 and 65%, depending on STI, as shown in Table 9.

Table 9: Total number of lab tests, positive tests and positivity rate (in %), number and proportion of reported STI cases and number and proportion of corresponding patient questionnaires by STI, Bulgaria

BULGARIA	Monthly questionnaire		Diagnosis Questionnaire	Patient Questionnaire
STI	# lab tests	# positive tests (%)	# reported STI-cases (%)	# corresponding questionnaires (%)
Chlamydia	5,833	530 (9.1)	285 (53.8)	182 (63.9)
Gonorrhoea	10,803	312 (2.9)	81 (26.0)	41 (50.6)
HIV	14,174	57 (0.4)	43 (75.4)	28 (65.1)
Syphilis	70,890	1571 (2.2)	187 (11.9)	82 (43.9)

6.1.2. STI-Trends

In Bulgaria, the positivity rate was highest for chlamydia in all reported quarters. It varied from 5.3% (54/1020) to 13.2% (38/289), however due to differing numbers of positives and tests, the positivity rate has to be interpreted cautiously and trends should be interpreted on a longer time-period.

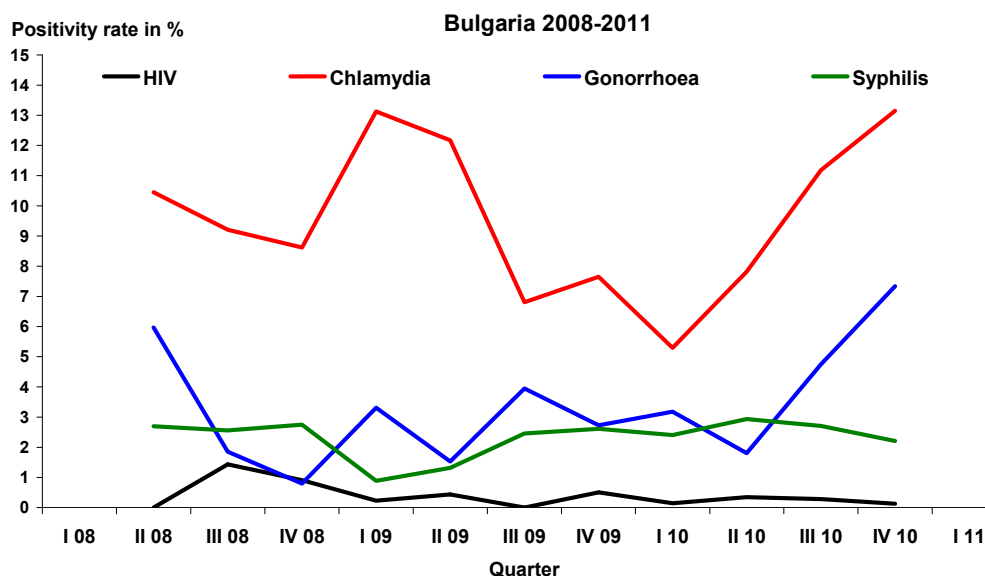

Figure 9: Positivity rate by STI in Bulgaria over time

6.1.3. Sociodemographic characteristics of patients with STIs

With 63% of patients with an STI/HIV being male, their proportion was more than two thirds. There were no differences in the age of patients, with a median age of 29 years for both genders. The proportion of migrants was with 1.6% among males and 1.2% among females comparable as well. 5% of patients belonged to the Roma community among both genders. There were statistically more CSW among females with 5%, however still being very few compared to other countries. No statistically significant differences existed for the proportion of IDU nor for a history of previous STI which had been had indicated by roughly $\frac{1}{4}$ of all patients (see Table 10).

Table 10: Demographics of patients with an STI/HIV in Bulgaria.

	Men (n=375)	Women (n=176)
Percentage	63%	37%
Age, median (years)	29	29
Migrant	1.6% (6/367)	1.2% (2/173)
Roma	15 (5%)	6 (5%)
Men who have sex with men (MSM)	17% (65/375)	--
Commercial sex worker (CSW)	2% (6/375)	5% (9/176)
i.v. drug use	2% (7/321)	3% (4/144)
History of STI	26% (98/375)	23% (41/176)

Data from diagnosis and patient questionnaires;
Questionnaires without indication of gender excluded.

The majority of all patients originated from Bulgaria. Other nationalities were less frequently reported (see Figure 10).

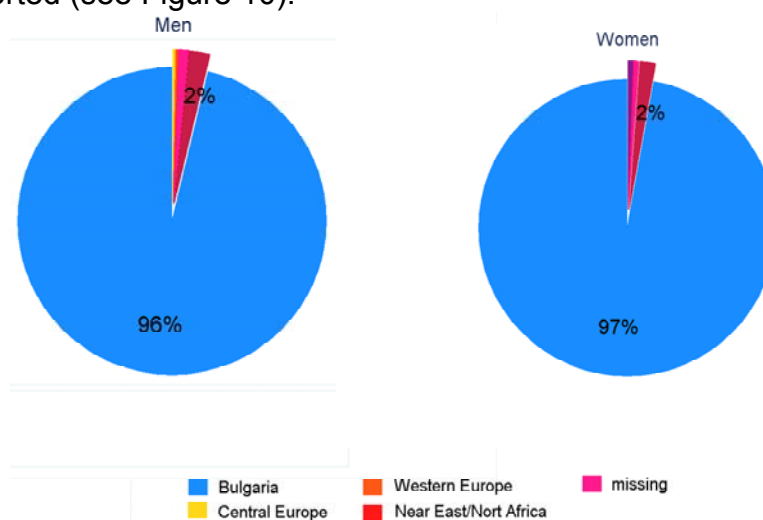

Figure 10: Origin of patients with STI in Bulgaria stratified by gender (n=551)

6.1.4. Epidemiology of STIs

Among all STI and HIV patients males were in majority. The most commonly diagnosed STI was chlamydia with more than 2/3 being of male gender. The second most common STI was syphilis, 62% being male (see Figure 11).

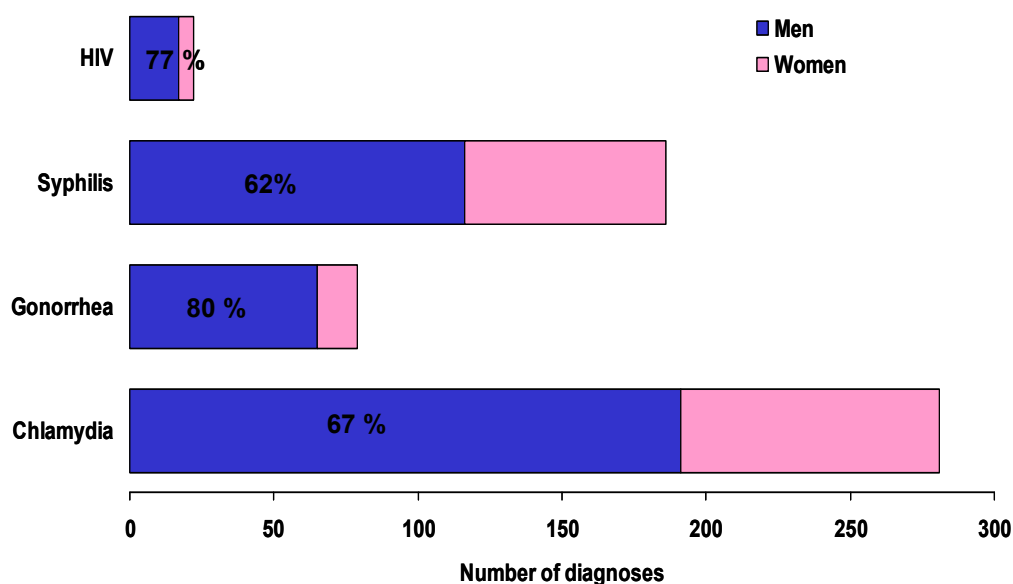

Figure 11: Number and gender distribution of STI/HIV among patients at Bulgarian sentinel sites

Stratified by STI/HIV there were no statistically significant differences in age between the genders. Median age was highest among syphilis patients (32 years for males and 29 years for females) and lowest for gonorrhoea (26 years in males and 22 years in females) (see Table 11). The highest number of male patients with STI belonged

to the age group 25 to 29 years, the lowest number to the group aged 60 and more. Female patients exhibited a very similar pattern with the biggest group being aged 25 to 29 years.

Table 11: Characteristics of patients (age, migrant, MSM and CSW) in Bulgaria by STI, stratified by gender

	Chlamydia		Gonorrhoea		Syphilis		HIV	
	Men (n=191)	Women (n=90)	Men (n=65)	Women (n=14)	Men (n=116)	Women (n=70)	Men (n=17)	Women (n=5)
Age, median (years)	29	29	26	22	32	29	30	37
Migrant	5 (3%)	1 (1%)	1 (2%)	0 --	1 (1%)	0 --	0 --	1 (20%)
MSM	25 (13%)	--	11 (17%)	--	29 (25%)	--	4 (24%)	--
CSW	3 (2%)	2 (2%)	1 (2%)	0 --	1 (1%)	7* (10%)	1 (6%)	0 --

* Statistically significant

Co-infection of more than one STI and/or HIV was in general diagnosed rarely; however, most commonly diagnosed for gonorrhoea and chlamydia. This co-infection had a similar distribution in both genders; however, more often in women (see Table 12) but overall numbers were rather small.

Table 12: Co-infections of chlamydia, gonorrhoea, syphilis and HIV in Bulgaria by gender

	Chlamydia		Gonorrhoea		Syphilis		HIV	
	Men (n=191)	Women (n=90)	Men (n=65)	Women (n=14)	Men (n=116)	Women (n=70)	Men (n=17)	Women (n=5)
Chlamydia	--	--	11 (16.9%)	3 (21.4%)	2 (1.7%)	0 --	0 --	0 --
Gonorrhoea	11 (5.8%)	3 (3.3%)	--	--	2 (1.7%)	0 --	0 --	0 --
Syphilis	2 (1.1%)	0 --	2 (3.1%)	0 --	--	--	0 --	0 --
HIV	0 --	0 --	0 --	0 --	0 --	0 --	--	--

* Statistically significant, only patients with known gender included

Another question concerned the history of a previous STI or diagnosis of HIV in regards of the current disease (see Table 13). A significant proportion of current patients has had the same STI previously, e.g. more than ten percent of chlamydia or gonorrhoea patients had the same disease before.

Table 13: Previous diagnosis of STI or HIV by current disease in Bulgaria

	Chlamydia (n=285)	Gonorrhoea (n=81)	Syphilis (n=188)	HIV (n=22)
Chlamydia	13.7%	5%	1.1%	0%
Gonorrhoea	10.5%	12.4%	2.7%	4.6%
Syphilis	2.1%	0%	9.6%	0%
HIV	0.4%	0%	0.6%	--

6.1.5. Groups at risk and risky behaviour

We compared the use of condoms among males and females (see Figure 12). Males were less likely to use condoms with their casual partner while women were less likely with their regular partner; statistically, however these differences were not significant.

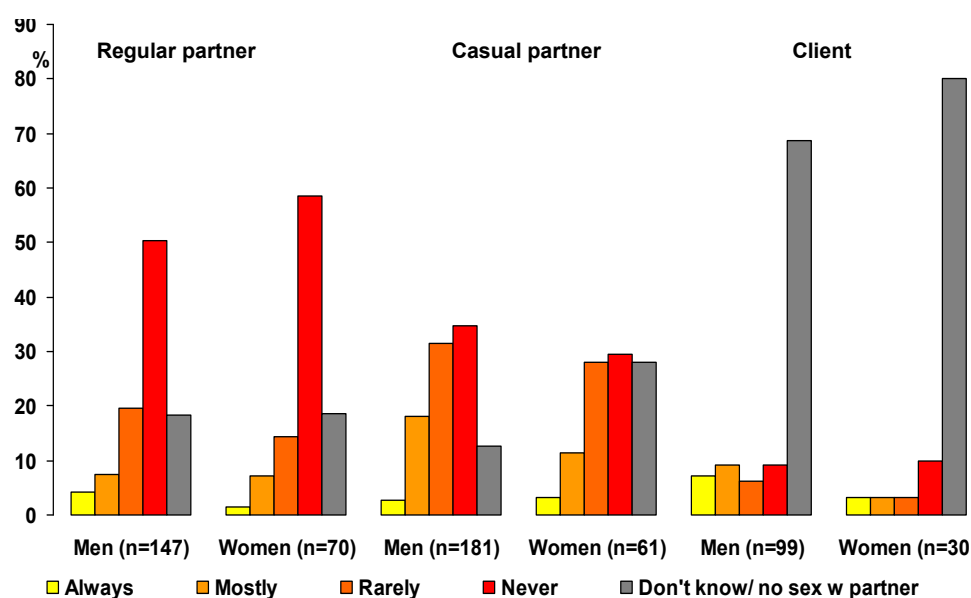

Figure 12: Condom use with regular and casual partner and CSW among patients attending Bulgarian sites, by gender

Number of sex partners was significantly differing between males and females ($p < 0.001$). Males ($n=91$) had a median of 3 and a mean of 5 sex-partners within the last 6 months while females ($n=46$) had a median of 2 and a mean of 3 sex-partners in this period.

The patient's questionnaire contained an item asking for the most likely source of the current infection. Table 14 shows the results stratified by group at risk. MSM assumed most often (in more than $\frac{3}{4}$ of all patients) a casual partner as source of their infection. A client, casual or an unknown partner was the main source of infection for FSW. There were statistically significant differences between male and female patients aged under 25 years: more males suspected a casual partner while females assumed more often their regular partner being the source of their current infection ($p = 0.024$).

Table 14: Suspected source of current infection (from patient's questionnaire) by group at risk in Bulgaria

	MSM (n=37)	FSW (n=7)	Migrant ♀ (n=0)	Migrant ♂ (n=2)	<25 years ♀ (n=16)	≥25 years ♂ (n=54)
Regular partner	10.8%	0	n.a.	0	37.5%	7.4%
Casual partner	75.7%	28.6%	n.a.	50%	50%	72.2%
CSW	2.7%	14.3%	n.a.	50%	0	3.7%
Client	0	28.6%	n.a.	0	0	0
Other/ don't know	10.8%	28.6%	n.a.	0	12.5%	16.7%

6.4. Limitations and first conclusions on the data from Bulgaria

Overall, numbers of diagnosed STI were small which limited statistical analyses. However, one interesting finding we couldn't interpret immediately was the high proportion of patients with syphilis. As we were informed during the on-site visit, testing for syphilis is still mandatory in Bulgaria on many occasions, such as taking up a new job, entrance of children in kindergarten, getting married, etc. which explains the number of tests.

Interpretation of data in regards of groups at risk is limited due to stigmatization of these patient groups. We might therefore underestimate the proportion of CSW, IDU or MSM among our patients. Migrants were of less significance in Bulgaria.

The gender distribution of STI and HIV shows a majority of males of varying degree: 80% males among gonorrhoea and 62% among syphilis. The most affected age group were the 25 to 29 years old among both genders, except for gonorrhoea which exhibited a shift to the left.

There were high proportions of STI patients with the same STI in their history; a possible explanation might be lack of knowledge. However, some groups such as MSM had very low figures which question the data reliability.

Source of infection varied by group at risk: MSM suspected mainly casual partners whilst the regular partner added to this risk in females less than 25 years of age. There were no statistically significant differences in condom use; however, both genders indicated very low proportions of regular condom use with any kind of partner.

As we noticed at our on-site visit, there is still a great lack of diagnostic options in Bulgaria. NAATs (nucleic acid amplification tests) are not readily available for chlamydia and gonorrhoea diagnosis and are very expensive for routine use or screening. Furthermore, the Bulgarian healthcare system is still not comparable to western European countries, and not all persons in the country have a health insurance. In regards of STIs this plays an important role, as many of the clients seen in our sentinel institutions lack of health insurance and/or are from a vulnerable group. Therefore, not all diagnostic tests can be performed, as patients would have to pay privately and cannot afford such tests.

In total, the participation of sentinel sites in Bulgaria was continuous and satisfying. In the future, doctors should be asked to complete more individual diagnosis questionnaires, particularly for patients with syphilis and gonorrhoea, as only for 12% and 26% of positives reported via monthly questionnaires, diagnoses questionnaires were sent. Recruitment of more Roma people would be desirable, as only 5% of all STI patients being Roma seems to underestimate the situation in the country. Similarly, only 5% of all women were reported being CSW which might not reflect the true situation. Anonymity of the study should be emphasized in order to enhance disclosure and hence improve data analyses according to groups most at risk.

7. Interim results from Romania

7.1. Composition of the Romanian sentinel sites

7.1.1. *Characteristics of Romanian sentinel sites*

We received data from 10 sites, including the locations from the predecessor project; 9 of them joined the BORDERNETwork and 1 participated in the earlier project only. As per April 2011, we received patient and diagnosis questionnaires from 4 of the sentinel sites which continued their participation. Participating institutions were dermato-venerological and infectious disease hospitals (3) and two NGOs, one of them focusing on HIV which maintains 2 outpatient locations and four mobile outreach units. With 40% (4) the majority of sites classified their **area of service** as focused on villages or smaller towns whilst 10% (1) served urban areas and 50% (5) lacked an answer to this question.

The **number of attending STI-patients** per site and month was 0 at one site (10%), 1 to 25 at three sites (30%) and more than 100 at 1 site (10%); five sites (50%) did not specify the number of attendees. The **number of attending HIV-patients** per site and month was 0 at two sites (20%), 1 to 25 at one site (10%) and more than 100 at two sites (10%) whilst five sites (50%) did not answer this question.

A specific **STI-consultation** was offered by four sites (40%) and an **HIV-consultation** by three sites. Six institutions didn't indicate the existence of such.

STI-testing was anonymous at one (10%) and free of charge at three (30%) sites (6 missing included); **HIV-testing** was offered anonymously at one (10 %) site and was **free of charge** at four (40%).

7.1.2. Attendees of the Romanian sentinel sites

The median proportion of **men among all attending STI patients** was 60% with a mean of 58% and a range from 50% to 65%. Among **HIV patients** the median and mean were 58% with a range from 50% to 65%.

The median proportion of **people of foreign origin** was 1% among all replying institutions among **STI patients** and with 0.5% even less among **HIV patients**.

In addition, sites had been asked for an estimation of the proportion of different groups at risk among their patients, stratified by gender (see Table 15).

However, it is difficult to interpret these numbers. The majority of patients among both genders belonged to heterosexual persons; however, the number of attended patients per site didn't enter this calculation. Therefore, it might very well be that the percentage of CSW or IDU is significantly different from these numbers when considering patients instead of sentinel sites.

Table 15: Median of proportions of different risk groups among patients in Romania (multiple answers possible)

			Median	Range
Women	Sex workers (CSW)		20%	10-40%
	i.v. drug user (IDU)		0.5%	0-1%
	Heterosexual		79%	60-100%
	Homo-/bisexual		10%	5-40%
Men	i.v. drug user (IDU)		1%	n.a.
	Heterosexual		92%	60-100%

7.2. Response rate in Romania

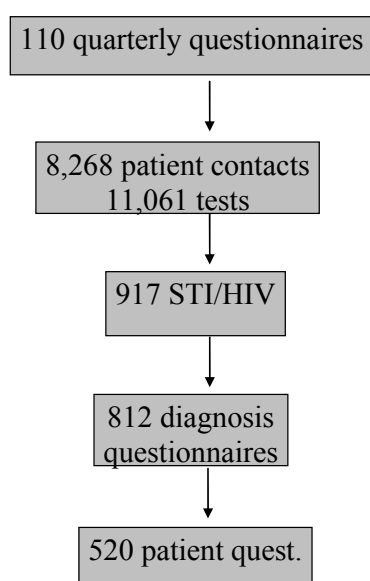

Physicians from participating institutions sent a diagnosis questionnaire in 89% (812/917) of patients with a positive diagnosis (see

Figure 13). Patients completed the patient's questionnaire in 64% (520/812).

Figure 13: Flow chart of questionnaires and number of positive tests in Romania

7.3. STI Surveillance data Romania

In Romania, the STI sentinel surveillance was introduced in 2008 and data were reported continuously until today.

7.1.1. Performed tests, positivity rates and reported cases by STI

Since the start of the sentinel surveillance in Romania in 2008, a total of 11,061 tests have been performed in 8,268 clients. In these data from the monthly questionnaires, doctors stated that 4,539 of all attending clients (54.9%) were men. Most tests were performed for syphilis, where also the highest number of positives was found. However, chlamydia had by far the highest positivity rate. In Romania, doctors filled in more individual questionnaires for chlamydia patients than reported on monthly questionnaires. Data clarification is pending. For only 36% of HIV-cases, a diagnosis questionnaire was filled out, compared to 97% of gonorrhoea cases. The patient response rate varied between 47 and 75%, depending on STI, as shown in Table 16.

Table 16: Total number of lab tests, positive tests and positivity rate (in %), number and proportion of reported STI cases and number and proportion of corresponding patient questionnaires by STI, Romania

ROMANIA	Monthly questionnaire		Diagnosis Questionnaire	Patient Questionnaire
	# lab tests	# positive tests (%)	# reported STI-cases (%)	# corresponding questionnaires (%)
STI				
Chlamydia	584	104 (17.8)	112 (107.7)	53 (47.3)
Gonorrhoea	1122	93 (8.3)	90 (96.8)	49 (54.4)
HIV	4187	56 (1.3)	20 (35.7)	15 (75.0)
Syphilis	5168	664 (12.9)	600 (90.4)	413 (68.8)

7.1.2. STI-Trends

In Romania, the positivity rate was highest for syphilis at the start of the study, namely 42.3%, but it then levelled off to approximately 7%. Possible explanations for the very high positivity rate in the 4th quarter of 2008 could have been low numbers of tests and positives reported, as the number of reported tests was much higher in the following periods. Overall, chlamydia had the highest positivity rate in Romania, but number of performed tests was fairly low compared to other STIs.

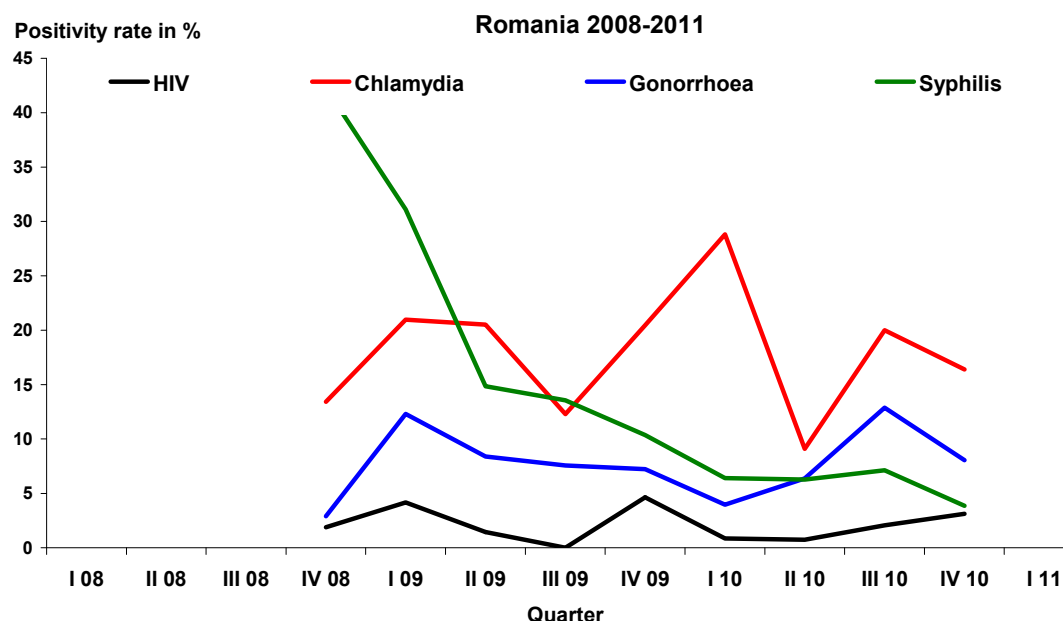

Figure 14: Positivity rate by STI in Romania over time

7.1.3. Sociodemographics of patients with STI/HIV

With 61% of patients with an STI/HIV being male, their proportion was almost two thirds in Romania, as well. Male patients had a median age of 30 years whilst median of females was 29 years ($p=0.03$). The proportion of migrants was below 1% whilst Roma made up 10% among both genders. The proportion of CSW was comparable between genders, too. A previous history of STI was more common among females ($p=0.04$). No intravenous drug-users with a new STI/HIV-infection were reported from Romania so far. Reasons for this have still to be clarified with the partners. (see Table 17).

Table 17: Demographics of patients with an STI/HIV in Romania

	Men (n=498)	Women (n=314)
Percentage	61%	39%
Age, median (years)	30	29
Migrant	0.9% (4/454)	0.4% (1/284)
Roma	10% (28/283)	10% (18/183)
Men who have sex with men (MSM)	5% (23/498)	--
Commercial sex worker (CSW)	3% (13/498)	5% (16/314)
i.v. drug use	0	0
History of STI	22% (111/498)	29% (90/314)

Data from diagnosis and patient questionnaires;
Questionnaires without indication of gender excluded

The majority patients originated from Romania. Other nationalities were less frequently reported (see Figure 15).

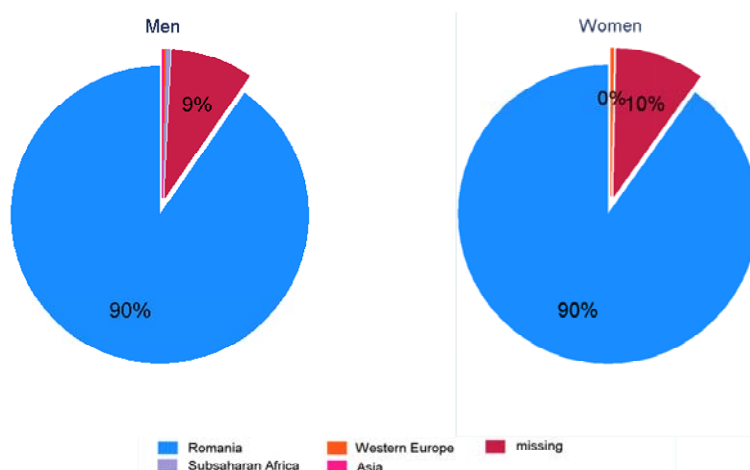

Figure 15: Origin of patients with STI in Romania stratified by gender (n=812)

7.1.4. Epidemiology of STIs

Among all STI and HIV patients males were the majority. The most commonly diagnosed STI was syphilis with more than 1/2 of patients being male. The other STI were diagnosed less frequently by far; second most common STI was chlamydia. Male gender was even more common among all other STI and HIV than among syphilis patients (see Figure 16).

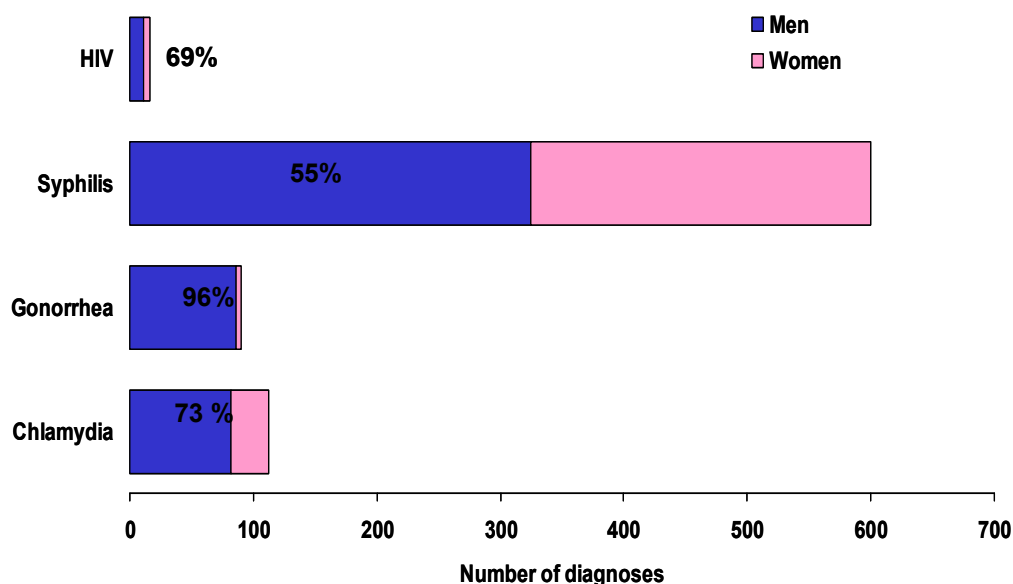

Figure 16: Number and gender distribution of STI/HIV among patients at Romanian sentinel sites

Stratified by STI/HIV there were statistically significant differences in age between the male and female patients with syphilis ($p < 0.001$). Median age was highest among

syphilis patients (33 years for males and 29 years for females) and lowest for gonorrhoea in females (25 years) and chlamydia in males (24 years) (see Table 18). The highest number of patients with STI belonged to the age group 20 to 24 years and the lowest number to the group aged 60 and more for both genders.

Table 18: Characteristics of patients in Romania (age, migrant, MSM and CSW) by STI and HIV, stratified by gender

	Chlamydia		Gonorrhoea		Syphilis		HIV	
	Men (n=82)	Women (n=30)	Men (n=86)	Women (n=4)	Men (n=325)	Women (n=275)	Men (n=11)	Women (n=5)
Age, median (years)	24	27	26	25	33	29*	31	29
Migrant	0	0	0	0	0	0	0	0
MSM	2 (2%)	--	5 (6%)	--	11 (3%)	--	5 (45%)	--
CSW	2 (2%)	0	1 (1%)	0	8 (2%)	16* (6%)	3 (27%)	0
Roma	3 (4%)	0	7 (8%)	0	18 (6%)	18 (7%)	0	0

* statistically significant

Co-infection of more than one STI and/or HIV was in general diagnosed very rarely; however, the most common co-infection was Chlamydia and gonorrhoea in men (see Table 19).

Table 19: Co-infections of chlamydia, gonorrhoea, syphilis and HIV in Romania by gender

	Chlamydia		Gonorrhoea		Syphilis		HIV	
	Men (n=82)	Women (n=30)	Men (n=86)	Women (n=4)	Men (n=325)	Women (n=275)	Men (n=11)	Women (n=5)
Chlamydia	--	--	5 (5.8%)	0	0	0	0	0
Gonorrhoea	5 (6.1%)	0	--	--	1 (0.3%)	0	0	0
Syphilis	0	0	1 (1.2%)	0	--	--	0	0

HIV	0	0	0	0	0	0	0	0
	--	--	--	--	--	--	--	--

only patients with known gender included

Another question concerned the history of a previous STI or diagnosis of HIV in regards of the current disease (see Table 20). Just for a current syphilis infection existed a significant proportion of previous STI: more than 14% claimed either chlamydia or syphilis in their past.

Table 20: Previous diagnosis of STI or HIV by current disease in Romania

	Chlamydia (n=112)	Gonorrhoea (n=90)	Syphilis (n=600)	HIV (n=16)
Chlamydia	1.8%	1.1%	14.4%	0%
Gonorrhoea	4.5%	2.2%	2.3%	0%
Syphilis	1.8%	3.3%	14.5%	6.3%
HIV	0%	0%	0%	--

7.1.5. Groups at risk and risky behaviour

We compared the use of condoms among males and females (see Figure 17). Males were less likely to use condoms with their casual partner and CSW (p<0.05) while women were less likely with their regular partner (p <0.05).

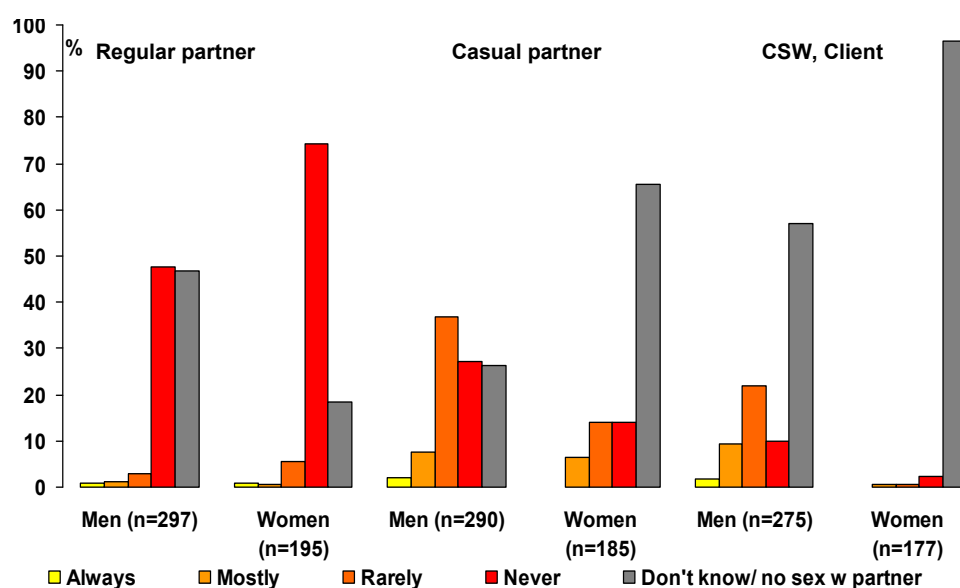

Figure 17: Condom use with regular and casual partner and CSW among patients attending Romanian sites, by gender

Number of sex partners was significantly different between males and females ($p < 0.001$). Males ($n=304$) had a median of 3 and a mean of 4 sex-partners within the last 6 months while females ($n=199$) had a median of 1 and a mean of 2 sex-partners in this period.

The patient's questionnaire contains an item asking for the most likely source of the current infection. Table 21 shows the results stratified by group at risk. MSM assumed most often (in 2/3 of all patients) a casual partner as source of their infection. Clients and casual partners were the main source of infection for FSW. There were statistically significant differences between male and female patients aged under 25 years: more males suspected a casual partner while females assumed more often their regular partner being the source of their current infection ($p < 0.001$).

Table 21: Suspected source of current infection (from patient's questionnaire) by group at risk in Romania

	MSM (n=60)	FSW (n=13)	<25 years ♀ (n=81)	<25 years ♂ (n=54)
Regular partner	8.7%	15.4	44.4	3.7
Casual partner	60.9	23.1	27.8	65.4
CSW	8.7	0	0	24.7
Client	8.7	23.1	5.6	1.2
Other/ don't know	13	38.5	22.2	4.9

7.4. Limitations and first conclusions on the data from Romania

Similarly to Bulgaria, the numbers of diagnosed STIs were small which limits statistical analyses. Also on our on-site visit in Romania we found out that syphilis testing is also quite common in Romania for various reasons. Furthermore, a national STI-programme exists which allows syphilis testing free of costs for anyone, also for people without health-insurance.

Like in Bulgaria, interpretation of data in regards of groups at risk is limited due to stigmatization of vulnerable populations. We might therefore underestimate the proportion of CSW, IDU or MSM among the patients recruited through sentinel institutions. Migrants did not play an important role. Furthermore, Romania is the only country in the whole of Europe where prostitution is prohibited and the law is still enforced. This criminalisation precludes open declaration and thus limits interpretation of data.

Although 5 of our sentinel institutions are drop-in clinics from our partner-NGO ARAS, which focuses on IDUs, we did not get any reports from IDUs. A possible explanation could be that these low-threshold clinics were only recruited recently and might not have had any new STI-diagnosis. Further the requirement for compliance

with the case definitions was made, and no reports of rapid-tests only should be made, hence if patients are sent away for confirmatory testing, the report through the sentinel site might be difficult.

Also due to these clinics, a selection bias of our sentinel sites might have occurred, making data comparison difficult. ARAS-clinics mainly focus on harm reduction in IDUs and therefore concentrate on HIV and hepatitis-testing (blood), whereas no swabs for chlamydia or gonorrhoea diagnosis are taken.

When analysing the basic questionnaires, we found out that the data quality could be improved, i.e. not all questionnaires were filled in completely and missing data were difficult to analyse.

Similar to the situation in Bulgaria we found a great lack of diagnostic options in Romania, with NAATs (nucleic acid amplification tests) not being available at all. Therefore a syndromic approach was chosen for treatment of STIs with discharge in Romania. Hence the low numbers of chlamydia tests are absolutely understandable. As serology is still performed for chlamydia diagnosis, one has to question if a comparison to other countries can be made at all. For the future, introduction of (generic, cheap) NAATs in the country are definitely the way to go. Gonorrhoea diagnoses are made by Gram stain, culture and resistance testing hardly being available at all in the country.

As in Bulgaria, the Romanian healthcare system is still not comparable to western European countries, and not all persons in the country have a health insurance, making routine STI-testing difficult particularly in persons with limited resources.

In Romania, we saw very small numbers of persons with co-infections. A possible mistake could have been that doctors reported each STI on a separate diagnosis questionnaire and it should be pointed out that one of these questionnaires has to be filled in by patient, not by STI. Further, we received more individual questionnaires for chlamydia patients than reported on monthly questionnaires. Data clarification is pending, and it should be made clear to doctors to send one diagnosis questionnaire only for each positive patient reported via the monthly questionnaires. For patients with new HIV-diagnosis, the report via the diagnosis questionnaire could however be improved.

8. Interim results from the Slovak Republic

8.1. Composition of the Slovakian sentinel sites

8.1.1. *Characteristics of the Slovakian sentinel sites*

Including the locations from the predecessor project we received basic questionnaires from 13 sentinel sites. As per April 2011 we received diagnosis and patient questionnaires from 8 of the sentinel sites. Participating institutions were public hospitals and medical universities (7) specialised in dermatovenereology (2), gynaecology (3), hepatology (1) and infectiology (1).

Further, “ambulancias” were recruited from policlinics (2) and specialised clinics (3) as well as one medical institution. Out of these 6 recruited doctors, there were 4 dermatovenereologists, 1 urologist and 1 hepatologist.

With 92% (12/13) the majority of sites classified their **area of service** as metropolitan whilst 8% (1) served a provincial area.

The **number of attending STI-patients** per site and month was 1 to 25 at eight sites (62%), 26 to 50 at two sites (15%), 51 to 75 at one site (8%) and more than 100 at one site (8%); one site (8%) did not specify the number of attendees. The **number of attending HIV-patients** per site and month was 0 at six sites (46%), 1 to 25 at four sites (31%) and more than 100 at two sites (15%); one site (8%) did not answer this question.

A specific **STI-consultation** was offered by six sites (46%) with no difference between urban and provincial locations. An HIV-consultation was offered by three sites (23%) with no difference between urban and provincial locations either.

The **number of employees** within the STI and HIV-sector at these sites varied between 1 and 4 with a mean of 2.

STI-testing was anonymous at four (31%) sites and free of charge at eleven (85%); **HIV-testing** was offered anonymously at seven (53%) sites and free of charge at eleven (85%).

8.1.2. Attendees of the Slovakian sentinel sites

The median proportion of **men among all attending STI-patients** was 70% with a mean of 66% and a range from 50% to 80% in those who answered this question. Among **HIV-patients** the median was 80% with a mean of 76% and a range from 50% to 100%.

The median proportion of **people of foreign origin** was 5% with a range from 0% to 10% for STI-patients and 1% with a range from 0% to 10% among HIV-patients, respectively. The respective means were 4% foreigners among STI-patients and 3% among HIV-patients.

In addition, sites had been asked for an estimation of the **proportion of different groups at risk** among their patients, stratified by gender (see Table 22).

However, it is difficult to interpret these numbers. The majority of patients among both genders belonged to heterosexual persons; however, the number of attended patients per site didn't enter this calculation. Therefore, it might very well be that the percentage of CSW or IDU is significantly different from these numbers when considering patients instead of sentinel sites.

Table 22: Median of proportions of different risk groups among patients in Slovakia (multiple answers possible)

			Median	Range
Women	Sex workers (CSW)		7.5%	0-20%
	i.v. drug user (IDU)		4%	0-70%
	Heterosexual		70%	0-99%
	Homo-/bisexual		10%	2-90%
Men	i.v. drug user (IDU)		5%	0-20%
	Heterosexual		75%	20-98%

8.2. Response rate in Slovakia

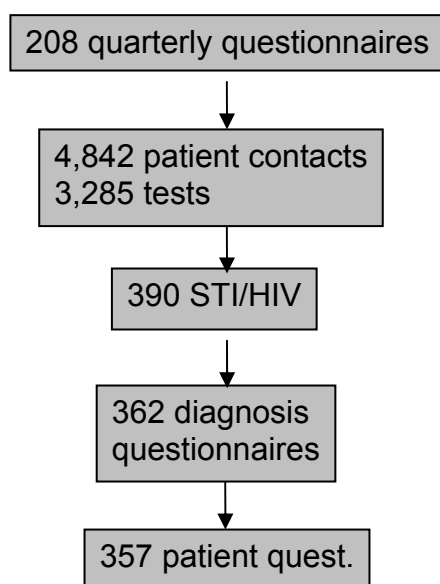

Physicians from participating institutions sent a diagnosis questionnaire in 93% (362/390) of patients with a positive diagnosis (see Figure 18). Patients completed the patient's questionnaire in 99% (357/362).

Figure 18: Flow chart of questionnaires and number of positive tests in Slovakia

8.3. STI Surveillance data Slovakia

In the Slovak Republic, the STI sentinel surveillance was performed in 2006 and 2007 under the Bordernet-project and from 2010 on as part of BORDERNetwork.

8.1.1. Performed tests, positivity rates and reported cases by STI

Since the start of the sentinel surveillance in Slovakia, a total of 3,285 tests have been performed in 4,842 clients. In these data from the monthly questionnaires, doctors stated that 2,068 of all clients (42.7%) were men. Most tests were performed for HIV, whereas the highest number of positives was found for syphilis. Syphilis also had the highest positivity rate by far. For each positive test, doctors were supposed to send one diagnosis questionnaire per patient. For gonorrhoea, more individual diagnosis sheets were filled out than positives reported on monthly questionnaires. Data clarification is pending. In almost 100% of positive syphilis diagnosis, doctors filled in an individual diagnosis questionnaire, whereas they only did so for 64% of HIV-cases. Patient response rate was very high, between 93 and 100% in all STIs, as shown in Table 23

Table 23: Total number of lab tests, positive tests and positivity rate (in %), number and proportion of reported STI cases and number and proportion of corresponding patient questionnaires by STI, Slovakia

SLOVAKIA	Monthly questionnaire		Diagnosis Questionnaire	Patient Questionnaire
	# lab tests	# positive tests (%)	# reported STI-cases (%)	# corresponding questionnaires (%)
STI				
Chlamydia	659	70 (10.6)	58 (82.9)	54 (93.1)
Gonorrhoea	382	34 (8.9)	52 (152.9)	51 (98.1)
HIV	1691	55 (3.3)	35 (63.6)	34 (97.1)

Syphilis	553	231 (41.8)	230 (99.6)	230 (100.0)
-----------------	-----	------------	------------	-------------

8.1.2. STI-Trends

In Slovakia, high positivity rates were found for all STIs, but particularly for syphilis at the start of the study. In the 2nd quarter of 2006, the syphilis positivity rate reached 79.4%. Similarly, the HIV-positivity rate was as high as 43.5% in the 4th quarter of 2007. Since the start of BORDERNETwork only very few data have been reported from Slovakia, also only starting in the 3rd quarter of 2010. Since then, all STI-positivity rates have been much lower than previously and will have to be monitored in the future.

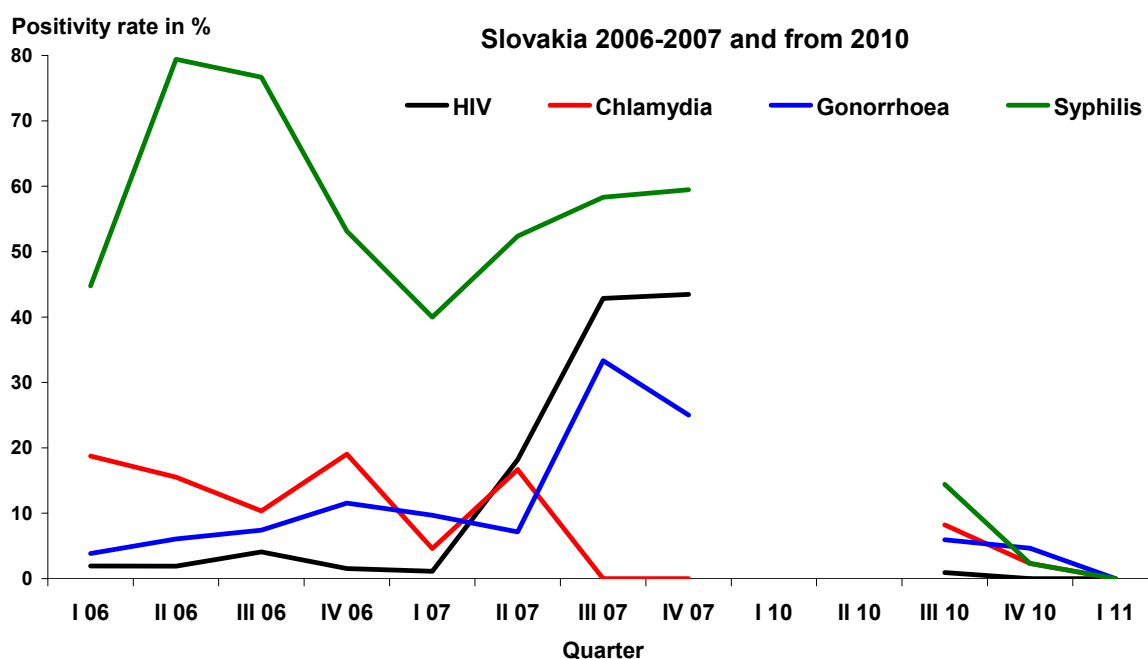

Figure 19: Positivity rate by STI in Slovakia over time

8.1.3. Sociodemographics of patients with STI

With 65% of patients with an STI/HIV being male, their proportion was almost two thirds in Slovakia, as well. Male patients had a median age of 34 years whilst median of females was 31 years ($p=0.01$). The proportion of migrants was below 10% among both genders. The proportion of CSW was higher among females. Intravenous drug use was more common among females ($p=0.001$). A previous history of STI was equally distributed for females and males (see Table 24).

Table 24: Demographics of patients with an STI/HIV in Slovakia

	Men (n=228)	Women (n=125)
Percentage	65%	35%
Age,median (years)	34	31
Migrant	10% (22/227)	10% (12/125)
Men who have sex with men (MSM)	31% (71/228)	--
Commercial sex worker (CSW)	9% (21/228)	22% (28/125)
i.v. drug use	4% (9/208)	16% (18/114)
History of STI	17% (39/228)	14% (18/125)

Data from diagnosis and patient questionnaires.
Questionnaires without indication of gender excluded.

The majority of patients originated from Slovakia. Other nationalities were less frequently reported; among males mainly other Central European countries and Eastern European for females (see Figure 20).

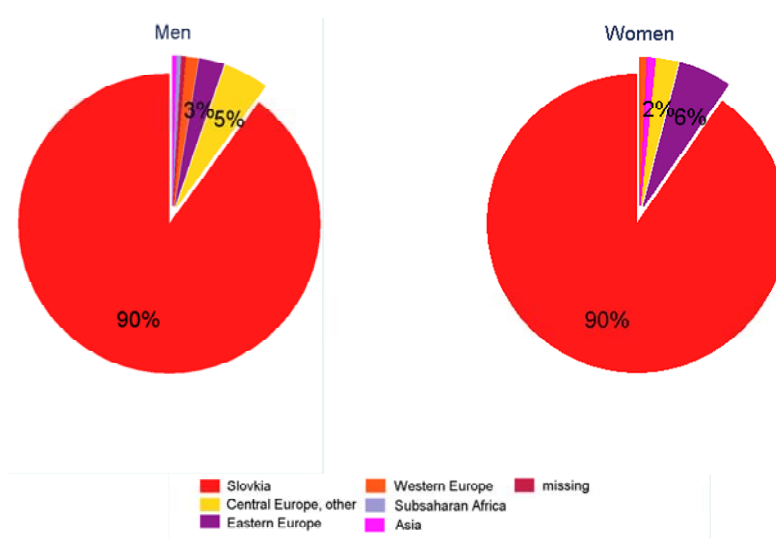
**Figure 20: Origin of patients with STI in Slovakia stratified by gender (n=353)**

8.1.4. *Epidemiology of STIs*

Among all STI and HIV males were the majority. The most commonly diagnosed STI was syphilis with more than 1/2 of patients being male. The other STI were diagnosed less frequently; the second most common STI being chlamydia. Male gender was

even more common among all other STI and HIV than among syphilis patients (see Figure 21).

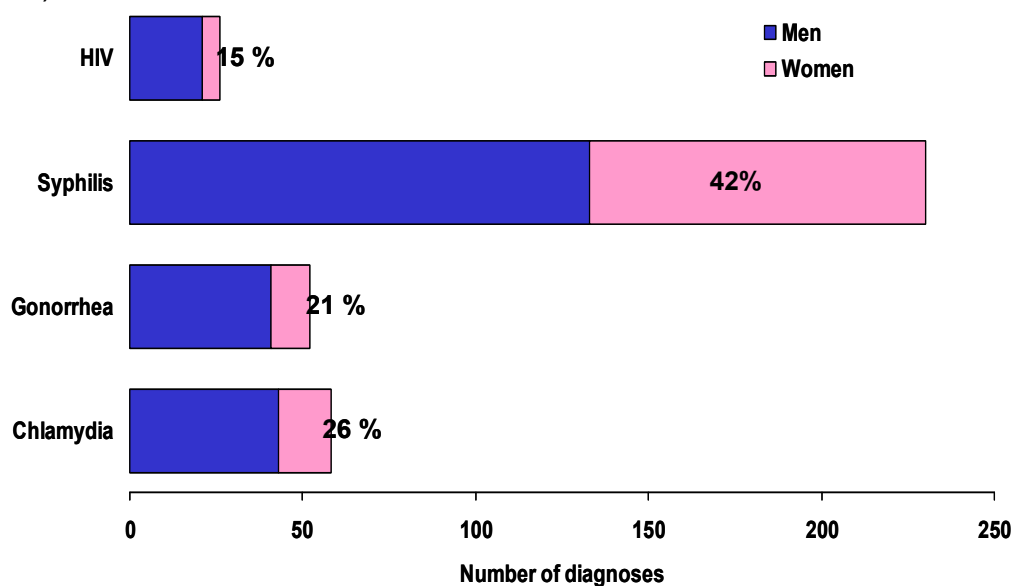

Figure 21: Number and gender distribution of STI/HIV among patients at Slovakian sentinel sites

Stratified by STI/HIV there were statistically significant differences in age between male and female patients with chlamydia ($p=0.02$) and syphilis ($p=0.02$). Median age was highest among chlamydia patients (37 years for males and 31 for females) and lowest for gonorrhoea (29 years in males and 25 in females; see Table 25). The highest number of patients with STI belonged to the age group 25 to 29 years and the lowest number to the group aged 20 or less in case of males and 30 to 34 and 20 or less for females, respectively.

Table 25: Characteristics of patients (age, migrant, MSM and CSW) in Slovakia by STI, stratified by gender

	Chlamydia		Gonorrhoea		Syphilis		HIV	
	Men (n=43)	Women (n=15)	Men (n=41)	Women (n=11)	Men (n=133)	Women (n=97)	Men (n=21)	Women (n=5)
Age, median (years)	37	31*	29	25	34	31*	30	29
Migrant	5 (12%)	1 (7%)	3 (7%)	1 (9%)	15 (11%)	11 (11%)	2 (10%)	2 (40%)
MSM	9 (21%)	--	9 (22%)	--	45 (34%)	--	13 (62%)	--
CSW	6 (14%)	6* (40%)	6 (15%)	1 (9%)	11 (8%)	19* (20%)	1 (5%)	2* (40%)

* Statistically significant

Co-infection of more than one STI and/or HIV was in general diagnosed very rarely (see Table 26).

Table 26: Co-infections of chlamydia, gonorrhoea, syphilis and HIV by gender in Slovakia

	Chlamydia		Gonorrhoea		Syphilis		HIV	
	Men (n=43)	Women (n=15)	Men (n=41)	Women (n=11)	Men (n=130)	Women (n=97)	Men (n=21)	Women (n=5)
Chlamydia	--	--	1 (2.4%)	1 (9.1%)	2 (1.5%)	1 (1%)	1 (4.8%)	1 (20%)
Gonorrhoea	1 (2.3%)	1 (6.7%)	--	--	1 (0.8%)	1 (1%)	2 (9.5%)	1 (20%)
Syphilis	2 (4.7%)	1 (6.7%)	1 (2.4%)	5 (9.1%)	--	--	3 (14.3%)	1 (20%)
HIV	1 (2.3%)	1 (6.7%)	0	0	3 (2.4%)	0	--	--

only patients with known gender included

Another question concerned the history of a previous STI or diagnosis of HIV in regards of the current disease (see Table 27). Almost 14% of patients with gonorrhoea reported this infection already in the past; more than a fifth of patients with chlamydia reported syphilis in their past.

Table 27: Previous diagnosis of STI or HIV by current disease in Slovakia

	Chlamydia (n=58)	Gonorrhoea (n=52)	Syphilis (n=227)	HIV (n=27)
Chlamydia	6.9%	1.9%	0%	0%
Gonorrhoea	12.1%	13.5%	0.9%	3.7%
Syphilis	22.4%	3.8%	5.3%	7.4%
HIV	0%	0%	1.4%	--

8.1.5. Groups at risk and risky behaviour

We compared the use of condoms among males and females (see Figure 22). Males were in general less likely to use condoms with a casual partner ($p=0.05$).

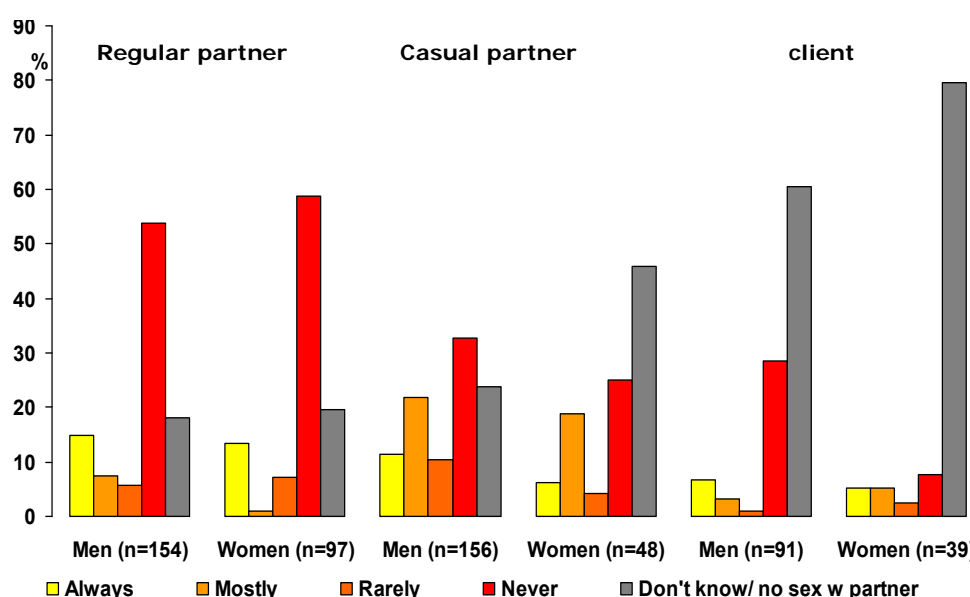

Figure 22: Condom use with regular and casual partner and CSW among patients attending Slovakian sites, by gender

Number of sex partners was significantly differing between males and females ($p < 0.001$). Males ($n = 175$) had a median of 2 and a mean of 3 sex-partners within the last 6 months while females ($n = 92$) had a median of 1 and a mean of 3 sex-partners in this period.

The patient's questionnaire contains an item asking for the most likely source of the current infection. Table 28 shows the results stratified by group at risk. MSM assumed most often a casual partner as source of their infection as did FSW. There were significant differences between genders among migrants: males suspected casual partners more often while women assumed it was their regular partner ($p < 0.001$).

Table 28: Suspected source of current infection (from patient's questionnaire) by group at risk in Slovakia

	MSM (n=69)	FSW (n=27)	Migrant ♀ (n=12)	Migrant ♂ (n=22)	<25 years ♀ (n=24)	<25 years ♂ (n=33)
Regular partner	15.9%	3.7%	58.3%	0%	45.8%	27.3%
Casual partner	66.7%	48.2%	8.3%	68.2%	20.8%	45.5%
CSW	0%	3.7%	0%	13.6%	4.2%	9.1%
Client	7.3%	37%	8.3%	4.6%	8.3%	3%
Other/ don't know	10.1%	7.4%	25%	13.6%	20.8%	15.2%

8.4. Limitations and first conclusions on the data from Slovakia

In total, the numbers of received questionnaires from Slovakia were very small. Therefore statistical analyses, particularly from subgroups are hard to perform. There were major difficulties at the start of BORDERNETwork, due to logistic reasons with the contract and therefore, the first questionnaires were only sent in the third quarter of 2010. In total, we received 210 monthly questionnaires, only 20 of them within BORDERNETwork and 362 individual diagnosis questionnaires, only 73 of them within BORDERNETwork.

Like in Austria, there was a break in the project, and therefore institutions had to be recruited again. In the future, continuous data collection should be preferred, as re-involvement in the project might be hard in some countries.

Within the cross-border meeting with Slovakian and Austrian participants it became apparent that migration of sexworkers across the border is assumed to play an important role. Also, it is very likely that clients of female sexworkers consume their services in Slovakia, but might attend Austrian healthcare facilities in case of symptoms. As reported by our Slovakian partners, migration of sexworkers from further east does not play such an important role in Bratislava. This can also be seen in the sentinel data, where at least 90% of men and women were from Slovakia.

Also, Slovakia is the only of our four sentinel surveillance-countries where more clients attended the sites than tests have been performed. So, our recruited sites in Slovakia see patients where no test is performed at all. This could be due to the fact that the majority being dermatology or gynaecology outpatient departments, where people might attend due to other reasons.

9. General discussion of the interim results and recommendations

A sentinel survey is not intended to provide representative population data. Therefore, a comparison of results on national level was not a goal of this project. However, the sentinel surveillance gathers useful information on groups most at risk and by using the same instrument in all four countries; our aim was to make it comparable. On the other hand, access to points of health care of some population groups, such as ethnic minorities is limited in some countries. Additionally, some risk groups are potentially difficult to reach, e.g. commercial sex workers (CSW) and intravenous drug users (IDU) or men who have sex with men (MSM); mainly due to fear of punishment or stigmatization.

Particularly for CSW, we found different legal issues in the four countries, for example sexwork being criminalized in Romania, compared to compulsory testing for registered sexworkers in Austria. Open declaration of MSM-status might pose a problem in some cultures and therefore the data for MSM found can be seen as minimum of all men.

Some of the participating countries experienced decades of centrally planned, so called "Semashko", health systems. These inheritances might have caused initial problems with data gathering, acceptance of NGOs and collection as well as social attitude and stigma towards the included STIs.

Different healthcare structures, as well as varying sentinel sites limit our comparison of results for all four countries as a whole. For example, Austrian data are strongly influenced by this one institution, which sent large amounts of data from female sexworkers, whereas the other three countries reported only small numbers of CSW

among all women. Comparing all women in one country to the other countries would bias the interpretation, and thus in the future certain vulnerable groups are planned to be compared between the four countries.

Also, particularly in Romania and Bulgaria, (compulsory) syphilis testing still plays an important role, and has to be regarded as a “historical relic”. In the future, efforts should be made to reconsider this testing strategy, as testing everyone for syphilis is very time-, labour- and cost-intensive, and the people currently tested might not be the ones at high risk. Testing parents before their child can attend kindergarten or bus drivers, etc. does not seem to reach the right targets, and a revision of the current national testing strategy is strongly recommended.

Furthermore, improvement of current diagnostic tests is strongly encouraged and anonymous and free-of cost tests would be desirable for STIs for everyone. Particularly the unavailability or not routine use of NAATs for chlamydia diagnosis should be tackled in the future, as only early diagnostic and treatment can prevent further spread. Evaluated non-approved NAATs might be a much cheaper option for resource-poor settings, as recommended by Domeika et. al.

Furthermore, use of culture for gonorrhoea diagnosis is not the routine test in many settings, resulting in very poor knowledge about the resistance situation in the country. As antimicrobial resistance in *Neisseria gonorrhoeae* can become a problem in the future, efforts should be made to monitor the situation in the respective country, and at least make culture available and affordable.

From the experience gained through the on-site visits, accessibility of institutions is important for vulnerable groups and all efforts should be made to reach low-threshold and minimal barriers for attendance in order to reach people who are most at risk for acquiring an STI or HIV. Outreach-work seems to play an important role too and can be used for prevention, as well as (minimal) healthcare support on the spot. It can also be seen as an “icebreaker” to minimise barriers for the usage of healthcare structures.

Last but not least, also our methodological problems have to be mentioned when implementing and improving the sentinel surveillance system. As already explained, motivation of participants is sometimes hard, particularly if there is a break in the surveillance system, as it was in Austria and Slovakia. A lot of effort had to be made in order to recruit the previous sentinel sites, as well as convincing possible future participants. Incentives in this process seem to play a minor role. By visiting some of the sentinel sites in our on-site-visits, we had the impression that data collection and quality improved substantially afterwards, as personal feedback and clarification of individual problems seem to be very important.

At the start of the study, we had to update the questionnaires and clarify with participants from the countries which diseases to include. Thereafter, hepatitis B was excluded from the Austrian questionnaires, and HPV and hepatitis C included in some of the other countries and the database had to be updated to allow data entry.

Data collection posed a particular problem in Slovakia, as the IDs from the previous project were partly mixed up or new institutions received the IDs from previous participants not allowing us to sum up data according to sentinel site. Some of these clarifications still have to be made as it seems difficult to work with so many partners and coordinators. Timeliness of data acquisition also seems to be a major problem of this, and we were now only able to analyse data up to January 2011, which does not allow timely recognition of any possible outbreaks or events. Efforts have already been made to improve this massive time delay by asking the sentinel sites to frequently deliver all questionnaires and also by asking the NGOs in the country to send it more frequently. In general, the way of data collection seems to involve too

many institutions, and data clarification can sometimes only be made half a year after the patients' attendance. Therefore, data quality is not always optimal and could be improved in the future. For future projects it is also recommended that data entry, plausibility control and analysis should be made at one centre, as typographical errors are frequent and cannot be solved when analysing the data without original questionnaires.

With this sentinel surveillance system, we intended to formulate policies and recommendations based on the data acquired. Particularly outstanding is the fact that biological data can be linked to (sexual) behaviour data. However, for these analysis, a large amount of patients is necessary, particularly when breaking it down to certain groups at risk or age groups, and for some countries, the results have to be interpreted cautiously.

Also, analysing trend seems to be difficult in such a short period of time, as testing frequencies and reported numbers vary substantially when breaking it down to quarters. A longer surveillance period would be preferable and should be pursued.

In general, the implementation and improvement of an STI-sentinel surveillance system has shown to be feasible at a relatively low cost and it has already delivered some important results which should be improved in the second part of the project.

10. Future plans

In the second half of the project, more data are expected in order to verify the first results. To interpret the data more precisely and improve the interpretation, the basic questionnaires should be looked at in more detail and the attempt be made to interpret the results according to the facility where patients were recruited. As a first step, the interpretation of information provided by doctors on the basic questionnaires has to be improved by weighting the estimation of "risk group" according to number of clients seen by each institution.

Further, a strong emphasis should be put in delivering the results to a wider audience as well as trying to formulate recommendations together with stakeholders and partners that can be implemented in the respective countries.

Indicators, as agreed on in the pre-start up meeting are tried to be met, all deliverables submitted in time and milestones produced.

11. Annex

11.1. Annex I: Glossary

Groups (at risk): Persons belonging to a group of people who are thought to be at risk or more vulnerable to acquiring an STI. For analyses, the following definitions from the data from diagnosis and patient questionnaires were made:

Migrants: either born in or holding citizenship of another country as stated by doctors or patients themselves

Men who have sex with men (MSM): Men who state themselves having had sex during the last 6 months with men or both gender, who thought that the gender of

their source of infection was male or male patients where doctors reported that the STI was most likely contracted via same-sex contact

Commercial sex workers (CSW): Person who stated him-or herself having received cash, drugs or accommodation in exchange for sex in the last 6 months, stating that they thought they were infected through a client, admitting sexual contacts with clients during the last 6 months or where doctors reported that the STI was most likely contracted via commercial sex work

Intravenous drug users (IDU): Person where the doctor reported intravenous drug use

Roma: Member of the Roma ethnic minority, as stated by doctors or patients themselves (in Romania and Bulgaria only)

Heterosexuals (not commercial): Persons who had sex with the opposite gender beyond commercial sex work

History of STI: Infections in medical history as stated by doctors, ever or within the last 12 months

HIV/STI case definitions: obligatory definitions for measurement of infections/diseases via use of specified diagnostic methods. Important to estimate quality of reported data and to ensure possibility of comparison of data reported by different sites

HIV-/STI-consultation: Consultation at the sentinel sites including diagnostics and treatment of HIV / STIs. Counselling could be existing sometimes, but is not obligatory

Positivity rate: Number of positive tests for a specific STI over the number of all performed tests for this STI

Sentinel site: a healthcare institution that is part of the STI sentinel surveillance reporting system

11.2. Annex II: List of sentinel sites (as by 30.6.2011)

Participation is completely voluntarily and might be terminated at any stage; therefore, the provided list might be subject to change. Included are all participants from Bordernet and BORDERNETwork who might have contributed data.

ID-Nr.	Name	Address	Branch of Study etc.
Austria			
500	OÄ Dr. Karoline Kandel	Kundratstraße 3 1100 Wien	SMZ Süd/Kaiser Franz Josef Spital; 4. Med. Abt. (Infektiologie u. Tropenmedizin)
501	Dr. Ewa Kosecka-Stehle, Dr. Christian Zagler	Sanatoriumstraße 2 1145 Wien	Sozialmed. Zentrum; Otto Wagner Spital der Stadt Wien; Pulmol. Zentrum/2. Med. Abt.

ID-Nr.	Name	Address	Branch of Study etc.
502	Prof. Dr. Geusau	Währinger Gürtel 18-20 1090 Wien	Allgemeines Krankenhaus der Stadt Wien; Univ.Klinik f. Dermatologie; STD-Ambulanz
503	OÄ Dr. Wasilewicz	Juchgasse 25 1030 Wien	KA Rudolfstiftung; Abt. für Allgemeine Dermatologie
504	Prim. Dr. Silvia Mayerhofer, Dr. Eva-Maria Vinzelj-Horvath	Neutorgasse 20 1010 Wien	STD-Ambulatorium der Stadt Wien (MA15)
505	Dr. Susanne Palfi	Franz Jonasplatz 8/2/3 1210 Wien	Pilzambulatorium Floridsdorf
506	Univ. Prof. Dr. Angelika Stary, Dr. Mojgan Taghizadeh-Safa, Dr. Michaela Mück	Schlüsselgasse 19 1080 Wien	Pilzambulatorium Schlüsselgasse GmbH
507	Univ. Prof. Dr. Angelika Stary, Dr. Claudia Heller-Vitouch	Lainzer Straße 58 1130 Wien	Pilzambulatorium Hietzing GmbH
510	Dr. Judith Hutterer	Blutgasse 5 1010 Wien	Practitioner (dermatologist, GP)
513	Dr. Gerlinde Balluch, Dr. Tamara Tedesch	Mariahilfer Gürtel 4 1060 Wien	Aids Hilfe Wien
514	PD Dr. Peter Komericki	Auenbruggerplatz 8 8036 Graz	Medizinische Universität Graz, Klin. Abt. f. Umweltdermatologie u. Venerologie
515	Dr. Carina Spak	Oberlaaer Straße 306 1100 Wien	Diakonie, Ambulante Medizin und Beratung, AMBER-MED
516	Markus Tritremmel, Dr. Lola Fleck	Schmiedgasse 38/1 8010 Graz	Aids Hilfe Steiermark,
517	Elisabeth Müllner	Blütenstrasse 15 4040 Linz/Urfahr	Aids Hilfe Oberösterreich
518	Dr. Peter Schmidt	Propst Führer Strasse 4 3100 St. Pölten	LKH St.Pölten, Dermatologische Ambulanz
519	Dr. Martina Schütz, Dr. Wolfgang Fuchs	Krankenhausstraße 9 4020 Linz	AKH Linz, Dermatologische Abteilung
520	Dr. Ninon Taylor	Müllner Hauptstraße 48 5020 Salzburg	LKH Salzburg, Dermatologische Abteilung
	Dr. Hans Haltmayer	Esterhazygasse 18 1060 Wien	Verein Wiener Sozialprojekte - Ambulatorium im Ganslwirt
508	Dr. Horst Schalk	Zimmremannplatz 1/1/4 1090 Wien	Praxisgemeinschaft Wien9 (GP specialized in HIV-care)
511	Dr. Lorenz Reiterer	Blechturm-gasse 26/6 1040 Wien	Practitioner (dermatologist, GP)
512	Dr. Wolfgang Jochmann	Johngasse 3 2460 Bruck an der Leitha	Practitioner (dermatologist, GP)
509	Dr. Bernd Gmeinhardt	Rembrandtstrasse 12 1020 Wien	Practitioner (dermatologist, GP)

Bulgaria

1002	Elena Djakova, MD	4000 Plovdiv	District Dispensary for Dermato-Venereal Diseases with Stationary
1003	Krasimira Chudomirova, MD, PhD	4000 Plovdiv	Department of Dermatology and Venereology, Medical University

ID-Nr.	Name	Address	Branch of Study etc.
1001	Dniela Markova, MD	9000 Varna	Multiprofile Hospital for Active Treatment "St. Ana " Unit 203
1004	Vasilka Kuzeva, MD	1000 Sofia	Dermato-Venerology District Dispensary for Dermato-Venereal Diseases without Stationary
1005	Elena Petrova, MD, PhD	1000 Sofia	Department of Dermatology and Venereology, Medical University

Romania

901	Dr. Vasile Benea	20125 Bucharest	Dermato-Venerological Unit, Clinical Hospital "Prof.Dr. Scarlat Longhin"
902	Cristina Munteanu	87000 Constanta	Dermato-Venerological Clinic in Hospital
903	Simona Atanasiu	Constanta	Baylor Marea Neagra Foundation
907	Raluca Teodorescu	Bd. 1 Decembrie 1918, nr 9J, sector 3, Bucharest	ARAS – Titan drop-in clinic
941	Dr. Gadiuta Mirela	Brasov	Public Health Department Brasov
942	Luminita Bosea	50000 Brasov	Hospital of Infectious Diseases
951	Raluca Teodorescu	Bucharest	ARAS (201.1)
952	Beatrice Marcu	Constanta	ARAS (201.2)
953	Lazarescu Otilia	Timisoara	ARAS (201.3)
954	Dr. Sorina CAPITANU, Petreo Catalin	Str. Pacii nr. 1, Piatra Neamt, jud. Neamt	VCT Community Centre ARAS (201.4)
955	Beatrice Manea	Iasi	ARAS (201.5)

Slovakia

601	Miloš Mokráš, MD, PhD.	Limbova 3 83305 Bratislava	Infectologist, FN Akad.L.Dérera, KIGM
602	Jaroslav Hinšt, MD, PhD.	Limbova 12 83301 Bratislava	Gynaecologist, Slovak Medical University
603	MUDR. KLIMENT MICHAL, CSc.	Limbova 5 83305 Bratislava	Gynaecologist (HPV), FN Akad.L.Dérera KLIN.ŽEN. CHOROB
604	prof. MUDr. J. Holoman, CSc.,	Limbova 12, 83301 Bratislava	Hepatologist, Slovak Medical University
605	Anna Čukasova, MD, PhD.	Limbova 5 83305 Bratislava	Gynaecologist (HPV), FN Akad.L.Dérera KLIN.ŽEN. CHOROB
607	MUDr. J. Elschekova,	Limbova 5 83305 Bratislava	Nestatna kozna ambulancia, FN Akad.L.Dérera
608	MUDr. Tomas Dianiska	Limbova 5 83305 Bratislava	Nestatna kozna ambulancia, FN Akad.L.Dérera
610	Igor Bartl, MD, PhD..	Ruzinovska 6 82606 Bratislava	Urologist, FN NSP RUŽINOV UROL.KLINIKA
611	MUDr. Peter Osusky, CSc.	Mickiewiczova 13 813 69 Bratislava	Dermatovenerologist, FN KOŽNÁ KLINIKA
612	Milena Osuská, MD	Mickiewiczova 13 813 69 Bratislava	Dermatovenerologist, FN KOŽNÁ KLINIKA
620	Gabriela Kolatorova	Líščie údolie 57 84104 Bratislava	Dermatovenerologist, DERMAVITA s.r.o.
621	doc. Mária Belovičová, MD, PhD.	09631 Bard. kúpele	Hepatologist, Interná amb. Bard.kúpele s.r.o.
623	Agáta Filkornová, MD	Strečianska 13 85105 Bratislava	Dermatovenerologist, FILACERM s.r.o.

11.3. Annex III: List of tables

Table 1: Median of proportions of different risk groups among patients in Austria by sex (multiple answers possible).....	10
Table 2: Total number of lab tests, positive tests and positivity rate (in %), number and proportion of reported STI cases and number and proportion of corresponding patient questionnaires by STI, Austria.....	11
Table 3: Demographics of patients with an STI/HIV in Austria	12
Table 4: Characteristics (age, migrant, MSM and CSW) of patients in Austria by STI, stratified by gender.....	14
Table 5: Co-infections of chlamydia, gonorrhoea, syphilis and HIV in Austria by gender	14
Table 6: Previous diagnosis of STI or HIV by current disease in Austria.....	15
Table 7: Suspected source of current infection (from patient's questionnaire) by group at risk in Austria	16
Table 8: Median of proportions of different risk groups among patients in Bulgaria (multiple answers possible)	18
Table 9: Total number of lab tests, positive tests and positivity rate (in %), number and proportion of reported STI cases and number and proportion of corresponding patient questionnaires by STI, Bulgaria.....	19
Table 10: Demographics of patients with an STI/HIV in Bulgaria.	20
Table 11: Characteristics of patients (age, migrant, MSM and CSW) in Bulgaria by STI, stratified by gender.....	22
Table 12: Co-infections of chlamydia, gonorrhoea, syphilis and HIV in Bulgaria by gender	22
Table 13: Previous diagnosis of STI or HIV by current disease in Bulgaria.....	23
Table 14: Suspected source of current infection (from patient's questionnaire) by group at risk in Bulgaria.....	24
Table 15: Median of proportions of different risk groups among patients in Romania (multiple answers possible).....	26
Table 16: Total number of lab tests, positive tests and positivity rate (in %), number and proportion of reported STI cases and number and proportion of corresponding patient questionnaires by STI, Romania	27
Table 17: Demographics of patients with an STI/HIV in Romania	28
Table 18: Characteristics of patients in Romania (age, migrant, MSM and CSW) by STI and HIV, stratified by gender	30
Table 19: Co-infections of chlamydia, gonorrhoea, syphilis and HIV in Romania by gender	30
Table 20: Previous diagnosis of STI or HIV by current disease in Romania	31
Table 21: Suspected source of current infection (from patient's questionnaire) by group at risk in Romania	32
Table 22: Median of proportions of different risk groups among patients in Slovakia (multiple answers possible).....	34
Table 23: Total number of lab tests, positive tests and positivity rate (in %), number and proportion of reported STI cases and number and proportion of corresponding patient questionnaires by STI, Slovakia	35
Table 24: Demographics of patients with an STI/HIV in Slovakia	37
Table 25: Characteristics of patients (age, migrant, MSM and CSW) in Slovakia by STI, stratified by gender.....	38
Table 26: Co-infections of chlamydia, gonorrhoea, syphilis and HIV by gender in Slovakia	39
Table 27: Previous diagnosis of STI or HIV by current disease in Slovakia	39
Table 28: Suspected source of current infection (from patient's questionnaire) by group at risk in Slovakia	40

11.4. Annex IV: List of figures

Figure 1: Geography of work-package 5 STI sentinel surveillance institutions.....	5
Figure 2: Information flow in the STI Sentinel Surveillance system	8
Figure 3: Flow chart of questionnaires and number of positive tests in Austria, 2006-2007 and from 2010.....	10
Figure 4: Positivity rate by STI in Austria over time	12
Figure 5: Origin of patients with STI in Austria stratified by gender (n=2,462)	13

Figure 6: Number and gender distribution of STI/HIV among patients at Austrian sentinel sites	13
Figure 7: Condom use with regular and casual partner and CSW among patients attending Austrian sites, by gender	15
Figure 8: Flow chart of questionnaires and number of positive tests in Bulgaria, since 2008	18
Figure 9: Positivity rate by STI in Bulgaria over time	20
Figure 10: Origin of patients with STI in Bulgaria stratified by gender (n=551)	21
Figure 11: Number and gender distribution of STI/HIV among patients at Bulgarian sentinel sites	21
Figure 12: Condom use with regular and casual partner and CSW among patients attending Bulgarian sites, by gender	23
Figure 13: Flow chart of questionnaires and number of positive tests in Romania.....	26
Figure 14: Positivity rate by STI in Romania over time	28
Figure 15: Origin of patients with STI in Romania stratified by gender (n=812)	29
Figure 16: Number and gender distribution of STI/HIV among patients at Romanian sentinel sites....	29
Figure 17: Condom use with regular and casual partner and CSW among patients attending Romanian sites, by gender.....	31
Figure 18: Flow chart of questionnaires and number of positive tests in Slovakia	35
Figure 19: Positivity rate by STI in Slovakia over time	36
Figure 20: Origin of patients with STI in Slovakia stratified by gender (n=353)	37
Figure 21: Number and gender distribution of STI/HIV among patients at Slovakian sentinel sites.....	38
Figure 22: Condom use with regular and casual partner and CSW among patients attending Slovakian sites, by gender	40